



**Above all – Accuracy and Reliability**



The Dresser Series C rotary product line includes innovative design features that reduce installation and maintenance costs while improving measurement accuracy by utilizing state-of-the-art components and advanced manufacturing technology.

Natural gas companies worldwide use Dresser rotary meters in commercial and industrial natural gas measurement applications. Our rotary meters are also used in both high flow residential applications and low volume transmission applications. Dresser Series C rotary meters are used at the well head gathering line, compressor stations, gas distribution systems, and end users such as chemical and processing plants. Meters of standard construction are used in the measurement of a variety of filtered and dry non-corrosive gases, including specialty gases.

### Operating Principle

Dresser rotary meters are designed to measure the volume of gases and gas mixtures with a high degree of accuracy. The rotary type positive displacement operating principle ensures permanent, non-adjustable accuracy by using precision machined two-lobe impellers encased within a rigid measuring chamber.

Unlike other meter types, measurement accuracy is not affected by changes in gas specific gravity, pressure, or fluctuating flow. Dresser rotary meters may be used from atmospheric pressure to 16 bar with highly accurate measurement over a wide operating range.

### Series C Design Features

- Compact size and lower weight
- High performance rotor (impeller) profile for increased rangeability
- Superior strength ensures reduced sensitivity to pipe stress
- Decreased susceptibility to damage from pressure shocks
- Simplified maintenance and repair
- Multi-functional index



As shown in the picture, two contra-rotating impellers of two-lobe or “figure 8” design are encased within a rigid measuring chamber, with the inlet and outlet connections on opposite sides. Precision machined timing gears keep the impellers in correct relative position. Optimal operating clearances between the impellers, cylinder and headplates provide a continuous, non-contacting seal.

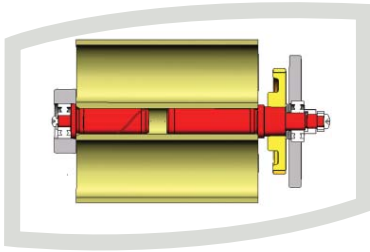

## Compact Size

With our innovative impeller, the compact and space saving Dresser Series C rotary meter is ideal for mounting in small meter stations or cabinets.

## Rotors

The precision, high performance rotors are held in place with four high quality main shaft bearings placed outside of the timing gears. This bearing placement strengthens the connection between the rotors and the timing gears. The sophisticated square profile impellers improve not only the accuracy, but also the rangeability of the meter by minimizing leakage between rotors and the body. This design also reduces the deflection of the rotor's main shafts at high flow rate and elevated pressure where dynamic loading is most prevalent. This feature makes the meter less vulnerable to damage during start up and operation.

## Rugged Design

The Dresser Series C rotary meter's rugged design is less sensitive to stress from misaligned pipe or flanged connections. Our compact meter body, thick flange connections, and stainless steel bearing support rings ensure easy installation, and robust performance in the most demanding installations. The square design rotors are also less susceptible to damage from rapid pressurization of the meter.

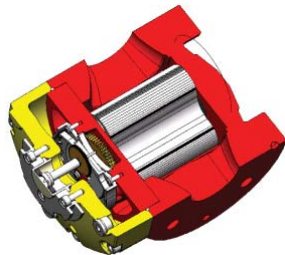

## Low Maintenance / Easy Repair

Repair technicians can replace all major parts without special tools. Dresser's innovative measurement cartridge simplifies most maintenance and repair activities. Technicians can remove the complete measurement mechanism (rotors, timing gears, and bearings) from the meter body in one piece. Whether you just clean the cartridge and re-install it, or replace the cartridge, major repairs are fast and easy. When regulations permit, users can also install a new prover certified cartridge.

## Multi Functional Index

Dresser Series C rotary meters utilize a magnetically coupled index. A "drive" magnet couples to the "follower" magnet of the index, which in turn drives the odometer on the meter index. The index can be removed or installed with just "one twist and a click". The magnetic coupling allows for orientation or exchange without decommissioning the meter.



A single index is adaptable to all Series C meter sizes due to the gear reduction internal to the meter body. The gear reduction is used to turn the drive magnet at an output ratio common to all Series C meters. By using a common index, the design enables standardization, reduces inventory and increases modular flexibility to its fullest extent. The Series C index also contains a pocket that can hold different types of Low Frequency (LF) pulse devices, such as reed switches, Wiegand sensors, or fraud detection/tamper indication devices.

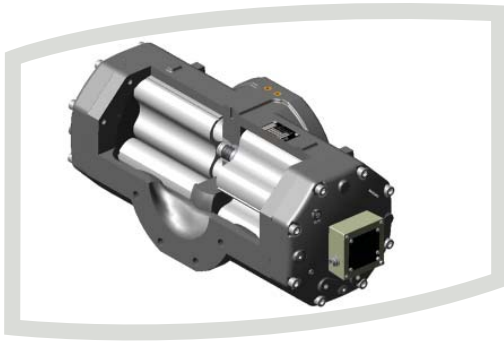

For applications requiring serial communication, the Series C index is available with an encoder. The encoder uses three optical sensors to detect light passing through a specially designed slotted disc rotating within the index. The light detected passing through the disc is converted to a numeric value using Gray Code. The system offers high resolution and allows for instant flow calculation.

The Series C index uses an 8 digit odometer and provides direct readings in cubic meters or cubic feet as per OIML R137-1. The index is 100% sealed and is IP 65 / IP 55 approved. Also, all Series C electronic devices are ATEX approved.

### Twin Impeller (Rotor) Principle

The figure-8 lobed impeller rotary meter design inherently creates pulsations as gas flows through the measurement chamber. This is a common and typical phenomenon with rotary meters. Resonance may affect the linearity of the calibration curve. The effect of such pulsations increases with pressure and the resultant resonance may affect components such as pressure regulators within the metering station. Harmonics, or the shift in frequency created by pulsations, can limit the achievable Qmax as the pressure in the measuring chamber varies.

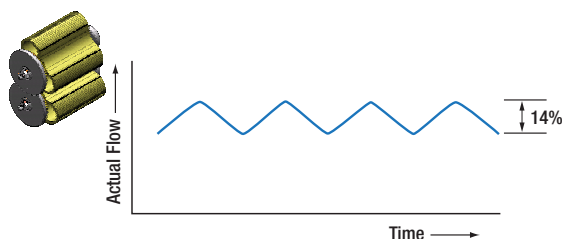

Harmonics is simply a column of air being resonated at its fundamental or lowest frequency. The small pulsation produced by the rotary meter occurs as the flow media quickly changes pressure as the measuring element (impellers) rotate. The amplitude of the pulsation from the measurement cavity is directly proportional to the pressure drop across the meter and the speed of the rotating device. These resonance flow points tend to show up as a higher than expected nominal value on the performance curve.

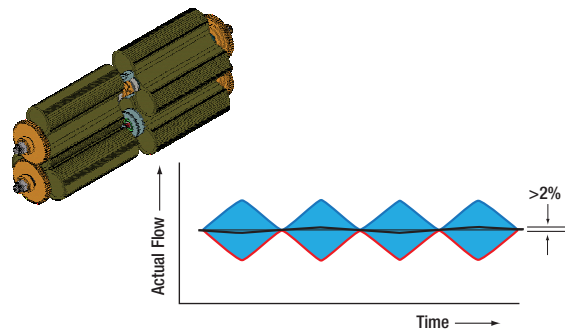

The Twin impeller principle, offered in the larger rotary meter sizes, divides the flow into two measuring chambers. The phase of each pair of impellers is shifted 45 degrees (180 degrees in terms of the sine wave) so that the pulsations are opposing and negligible, or eliminated.

Dresser Twin rotary meters provide significantly improved accuracy over conventional rangeability make them ideal choices for reference or master meter applications. Reduced pulsations also significantly reduce ambient noise, making Twin rotary meters ideal for sound sensitive applications.

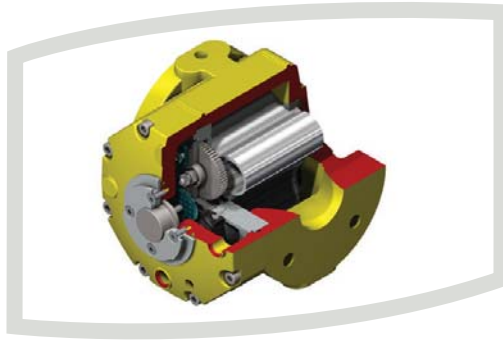

## The Advantages of the Series C Meter

- High accuracy & large rangeability (Qmax/Qmin ratio)
- Lighter weight - aluminum body
- Smaller overall dimensions, allowing compact metering stations
- Low pressure drop
- Low maintenance - lower Total Cost of Ownership (TCO)
- Reduced sensitivity to installation stresses - robust meter body
- Rigid design - reduced vulnerability to overloading and pressure shocks
- No requirements for minimum inlet and outlet piping runs
- Easy to view, single oil sight gauge
- Complies with the requirements of EN, OIML, ISO, PTB, EEC, DVGW and other international and national regulations and guidelines in different countries.

## Technical Data

### Applications

**Media:** Clean and dry natural gas, town gas, propane, inert gases

**Industry:** Commercial & Industrial gas supply, heating manufacturers, chemical industry

### Nominal pressure ratings

- PN10/16 (ANSI 150 optional)
- DIN and ANSI Flanges

### Nominal diameters

DN 40 – DN 150 (1-1/2" up to 6")

### Measuring range

From 30:1 to 160:1 (EN 12480)

### Flow rates

0,5 m<sup>3</sup>/h up to 1000 m<sup>3</sup>/h

### Repeatability 0,1 %

### Measuring accuracy

0,2 Q max to Q max : ± 1 % or better

Q min to 0,2 Q max : ± 2 % or better

### Temperature range

**Standard:** -25°C to +55°C,

**On request:** -40°C to +80°C

### Material

- Aluminium Alloy Body and Rotors
- High Grade Steel Alloy Shafts and Timing Gears
- Ductile Iron

## Approvals

The Dresser Series C meter is designed in accordance with relevant international standards including EC Directive MID 2004/22/EC, EN12480, OIML R137-1 and various National metrological approvals by NMI. Accredited according to the Pressure Equipment Directive (PED)

## Verification and Calibration

Dresser Series C meters are each supplied with a calibration certificate. The initial verification and calibration are carried out at the Dresser factory on an NMI and/or PTB approved calibration bench.

As an option, TWIN-Impeller Rotary Meters can be provided with a high pressure calibration from a certified test facility.



## Standard Features

The standard mechanical meter index is fitted with an LF output connector. Additional LF and HF outputs are available.

The meters are also fitted with a number of pressure and temperature measuring connections at the inlet and outlet, suitable for easy connection of electronic gas volume conversion devices such as the Dresser Micro Corrector and for ease in differential monitoring.

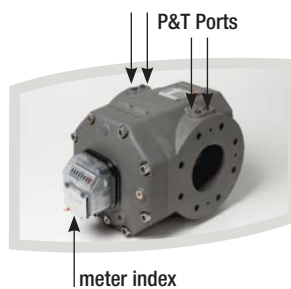

- A single oil level indicator (sight gauge) is located directly below the index. The oil reservoir should be filled after the meter has been installed. A bottle with sufficient lubrication oil for the initial filling is supplied with every meter. The oil reservoir should be filled until the oil level reaches the middle of the sight glass.

## Installation

- The Dresser Series C design permits very compact M&R stations without sacrificing the meter's accuracy.
- All Series C meters are designed for outdoor installation. The Index is IP 65 / IP55 approved.
- Gas pipes must be clean and free from foreign impurities such as sand, dirt, welding debris and other particles, as well as liquid.
- Generally it is recommended that a gas filter be installed upstream of the rotary meter, with a 160  $\mu$  filtration size.
- Check the flow direction of the meter against the required installation.



Oil level sight gauge

**The Dresser Series C meter has been designed for rigorous natural gas measurement applications and able to withstand typical starting up operations without degradation of performance or quality. However, to ensure an extended lifetime, care must be given while pressurizing the meter to prevent excessive over-speeding and damaging the rotating parts.**

**Table 1** - Measurement Ranges and Pulse Data

G-Rating	Comparable USA Rating	Q-max Rated Capacity (m <sup>3</sup> /h)	Rangeability	2 x Low Frequency Pulses (pulses/m <sup>3</sup> )
G 10	8C	16	1:30	10
G 16	8C	25	1:50	10
G 25	15C	40	1:80	10
G 40	2M	65	1:100	10
G 65	3M	100	1:160	10
G 100	5M	160	1:160	1
G 160T	11M	250	1:160	1
G 160	11M	250	1:160	1
G 250	16M	400	1:160	1
G 400T - 4"	23M	650	1:160	1
G 400T - 6"	23M	650	1:160	1
G 650T	38M	1000	1:160	1

**Table 2** - Dimensions and Weights

G-Rating	Number of Bolts	Flange Size		Overall Flange to Flange Dimensions	Height & Depth		Overall Weight in Kg (Approx. Values)
		inch	mm		mm	mm	
G 10	N.A.	1½ & 2	40 & 50	121*	130	200	5
G 16	N.A.	1½ & 2	40 & 50	121*	130	200	5
G 25	N.A.	1½ & 2	40 & 50	121*	130	220	5
G 40	4	1½ & 2	40 & 50	171	180	220	10
G 65	4	2	50	171	180	220	10
G 100	4/8	3	80	171	200	280	13
G 160T	4/8	3	80	171	200	350	21
G 160	4/8	3	80	241	225	315	27
G 250	8	4	100	241	225	400	30
G 400T - 4"	8	4	100	241	225	510	43
G 400T - 6"	8	6	150	241	285	510	50
G 650T	8	6	150	241	285	680	61

Note: GxxxT=Twin sets of rotors

\*: Without Flanges

## **About Dresser® Meters and Instruments**

Dresser is a leading supplier of ROOTS® rotary gas meters, turbine gas meters, and diaphragm gas meters. Dresser is your source for accurate, dependable and low maintenance natural gas meters, instruments and provers. Above all – accuracy and reliability.

## **About Dresser, Inc.**

Dresser, Inc. is a leader in providing highly engineered infrastructure products for the global energy industry. The company has leading positions in a broad portfolio of products, including valves, actuators, meters, switches, regulators, piping products, natural gas-fueled engines, retail fuel dispensers and associated retail point-of-sale systems, and air and gas handling equipment. Leading brand names within the Dresser portfolio include Dresser Wayne® retail fueling systems, Waukesha® natural gas-fired engines, Masoneilan® control valves, Consolidated® pressure relief valves, and Roots® blowers. It has manufacturing and customer service facilities located strategically worldwide and a sales presence in more than 100 countries.

### **Dresser, Inc.**

16240 Port Northwest Drive  
Houston, TX 77041-2645  
T. 832 590 2303  
F. 832 590 2494

### **Dresser Meters & Instruments**

7051HS Varsseveld  
The Netherlands  
T: +31 (0) 31527 1100  
F: +31 (0) 31527 1105

