

Nexus[®] 1500

Transient Recorder and Power Meter With Advanced Power Quality and Communication

- Accu-Measure Auto-Calibrating Metrology
- 0.06% Energy Accuracy
- Perfect Choice for Critical Applications
- Color Touch Screen Display
- Ultra-High Performance

*Really New and
Really Different*



Communication, I/O and User Interface

- Standard 10/100BaseT Ethernet Port
- Expandable Serial Ports (Dual RS485 Ports)
- Modbus ASCII, Modbus TCP, DNP 3.0 Level 2
- 8 Simultaneous Connections via Ethernet
- Optional Second Ethernet Port
- Vivid 256 Color Display
- Optional 100BaseT Fiber Optic Port
- Data Download Speed 20 Times Faster Than Existing Technology
- Up to 16 Relay Outputs
- Up to 40 Digital Status Inputs

New Generation Transient Recording Power Quality Analysis

- 10MHz Transient Recorder (over 166,000 Samples per Cycle)
- 8 Channel Waveform Recorder
- Voltage Surge, Sag and Transient Recording
- Current Fault Signatures and Analysis
- 1 Gigabyte Memory – Highly Extensive Recording Capability

www.electroind.com



Electro Industries/GaugeTech
The Leader in Power Monitoring and Smart Grid Solutions



ELECTRICAL & ELECTRONIC
MEASURING & TEST EQUIP.
64JA

Introduction

From today's utility giants or Fortune 100 companies, to local electrical municipals, an effective energy management and power monitoring program is critical to success. The Nexus® 1500 meter is the most advanced monitoring product on the market today, providing you with the total picture of energy usage and power quality from any metered point in a power distribution network, allowing you to make power related decisions quickly and effectively.

- Technology specifically designed for Utilities and Industry
- Real Time power quality monitoring and analysis identifies PQ and reliability events quickly
- Manage peak demand electrical power usage
- Report data quickly and reliably using Ethernet or serial communications
- Advanced transient analysis for critical power systems
- Also the perfect solution for Circuit Breaker or Transformer monitoring

The Perfect Monitoring Choice for Critical Applications

- Utility Transmission Line Substations
- Power Generation
- Highly Critical Industrials
- Hospitals / Medical

High Performance Revenue Metering Features

- **Extensive Load Profiling:** log virtually unlimited historical trending.
- **System Events (Anti Tampering):** the unit provides extensive usage information for detection of unauthorized access. The unit records:
 - Resets
 - Programming changes
 - Password Access changes
 - Time changes
 - Power Up/Down
 - Change of firmware
- **Transformer Loss and Line Loss Compensation:** for both iron and copper and total substation losses.
- **Load Aggregation/Universal Metering:** pulse inputs can be used to aggregate or accumulate different loads; utility products such as gas and water can also be accumulated.
- **Time of Use Capability:** bi-directional consumption and demand; 20 year calendar.
- **Max/Min Integration and Recording:** time-stamped max and min values for all measured readings.
- **Coincidental Readings:** identify number of capacitors needed, peak inefficiencies, etc.
- **Password Protection Prevents Unauthorized Tampering:** User programmable passwords.
- **Predicted Demand:** The meter uses rate of change to predict the peak demand of the next demand interval. Perfect for proactive load shedding.

Accu-Measure™ Auto-Calibrating Measurement Technology

EIG's patented Accu-Measure™ Auto-calibration technology allows a field-mounted metering device to achieve precision accuracy and maintain the accuracy over temperature and time. This technique is unique to EIG and consists of precise measurement technology and high precision internal reference standards.

Accu-Measure™ Technology features:

- 8 Independent High-Speed 16-Bit A/D Converters.
- Internal Reference for periodic Auto-calibration.
- Internal temperature sensor to sense deviations in instrument temperature.
- Designed to allow for repeatable and consistent energy measurement results.

Benefits of Auto-Calibrating Technology:

- Improves accuracy over temperature.
- Improves repeatability, reducing meter settling time.
- Improves long-term stability.
- Relies on precision internal DC references to maintain accuracy.

PARAMETER	200 msec*	1 SECOND*	DISPLAY RESOLUTION
Voltage (L-N)	0.1%	0.05%	5 Digit
Voltage (L-L)	0.1%	0.05%	5 Digit
Current	0.1%	0.025%	5 Digit
Frequency	0.03 Hz	0.01 Hz	5 Digit
kW @ Unity PF	0.1%	0.06%	5 Digit
kW @ 0.5 PF	0.1%	0.1%	5 Digit
kVA	0.1%	0.08%	5 Digit
kVAR (0.5-0.9 PF)	0.1%	0.08%	5 Digit
PF	0.1%	0.08%	3 Digit
Harmonic Magnitudes	N/A	0.2%	3 Digit
kW-hours	N/A	0.04%	16 Digit
kVA-hours	N/A	0.08%	16 Digit
kVAR-hours	N/A	0.08%	16 Digit

* Note: Readings are in percent of reading where applicable (more accurate standard), not in percent of full scale (less accurate standard).

V-Switch™ Technology

The Nexus® 1500 meter is equipped with EIG's exclusive V-Switch™ technology, which enables meter upgrades in the field without removing the meter from service. Nexus® 1500 V-Switch™ keys include:

- **V1:** Standard Nexus® 1500 meter with 128 Megabytes memory + 512 samples per cycle
- **V2:** V1 + 1 Gigabyte total memory + 1024 samples per cycle
- **V3:** V2 + 10MHz Transient Recording

Detailed Power Quality Analysis and Waveform Recording

EIG's Nexus® 1500 meter is one of the industry's premier fault and voltage disturbance recorders. This instrument captures a comprehensive picture history of voltage reliability and power quality events within mass memory for detailed and extensive forensic engineering analysis.

16 Bit Waveform and Fault Recorder:

- Record up to 1024 samples per cycle consisting of transient captures at over 166,000 samples per cycle.
- Voltage and current recording with pre and post-event analysis.
- Fault recording offers 8 times full scale capture capability.
- 16 bit A/D converter provides precise waveform resolution.
- Both hardware and software triggers available.
- View harmonic magnitudes to 512th order for each voltage and current channel.
- Real time harmonic magnitudes are resolved to the 128th order.
- Percent THD and K-Factor.
- Conduct power quality analysis at the high end of the harmonic magnitude spectrum.

High-Speed Status Input Triggers:

- Waveforms are recorded at time of status change.
- Input change and waveform recording are time-stamped to a 1 msec resolution.

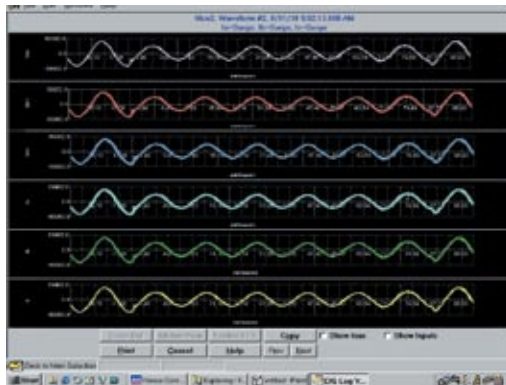

Multi-channel Waveform Recorder

EN61000-4-15 Flicker Meter:

- Flicker compliant with EN61000-4-15 standard.
- Operates on both 220 Volt/50 Hz and 120Volt/60Hz voltages throughout standard test points.
- EN61000-4-30 Reporting.

Subcycle 10MHz Transient Recorder (V3 Option):

Transients often cause intermittent, expensive periods of downtime. The subcycle transient recorder allows you to:

- Record subcycle transients at 10MHz resolution.
- Monitor switching noise from capacitors, static transfer switches, SCRs, and other devices that negatively impact power quality.
- This feature is essential for critical applications such as hospitals, wafer-fabs plants, data centers and other highly power quality sensitive applications.

Independent ITIC/CBEMA Log Plotting:

- Quickly view total surges, sags, and average duration in the independent ITIC/CBEMA log.

Phasor Analysis:

- The monitor reads a phase angle analysis between the voltage and current channels, allowing you to analyze efficiency and system integrity.



Phasor Analysis

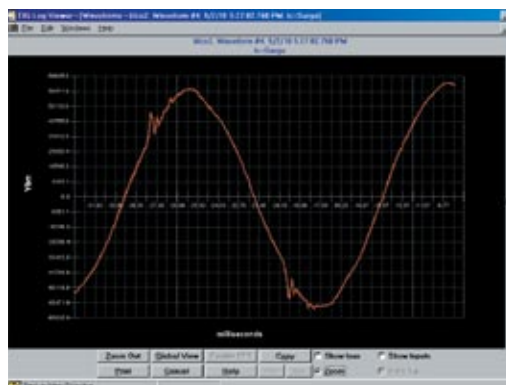

Sub-cycle Transients with 10 MHz Pickup Frequency

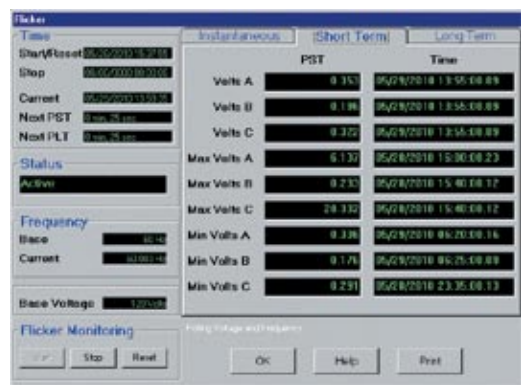

EN61000-4-15 Flicker Compliance

On-Board Communication for Every Application

Standard Communications:

- 100 BaseT Ethernet RJ45 Port
- ANSI Optical Port and USB 2.0 port

8 Built-In Digital High-Speed Status Inputs:

- Inputs automatically sense whether the circuit is externally wetted
- If externally wetted, input up to 150VDC is accepted
- If internally wetted, the meter supplies the necessary voltage for the control application.

Sync. Check-Aux. Volt Input—High-speed Vaux input can be used for:

- Neutral to ground or aux voltage readings
- Synchronizing schemes
- Obtain the freq, magnitude, and phase angle on both sides of a switch, or between generator and bus voltage for synch schemes.

Optional RS485 and Second Ethernet Port:

- Two identical built-in serial ports: Up to 115k baud
- Standard protocols include Modbus RTU/ASCII and DNP 3.0 Level 2
- Also available, second Ethernet port, either RJ45 or Fiber Optic
- Separate MAC address and configuration for each Ethernet port.

Industry Leading DNP 3.0 Level 2 Plus —complies with DNP Level 1 and Level 2 certification requirements, plus:

- Up to 136 measurements (64 Binary Inputs, 8 Binary Counters, 64 Analog Inputs) can be mapped to DNP static points in the customizable DNP Point map
- Up to 16 relays and 8 resets can be controlled through DNP
- Report-by-exception processing (DNP Events) deadbands can be set on a per-point basis
- 250 available events, of combinations of four events (Binary Input Change, Frozen Counter, Counter Change, Analog Change)
- Available Freeze commands: Freeze, Freeze/No-Ack, Freeze with Time, Freeze with Time/No-Ack
- Freeze with Time command enables the meter to have internal time driven Frozen Counter and Frozen counter event data
- **NEW** Programmable secondary scale allows users to maximize 16 bit analog input resolution precisely around the desired parameters providing enhanced resolution to SCADA.

Rapid Response™ Ethernet – Download data over 20 times faster than existing Nexus® technology

- Rapid Response™ 10/100BaseT Ethernet allows for 8 simultaneous connections of Ethernet Modbus TCP protocol. Two sockets for DNP 3.0 protocol are also available. Rapid Response™ technology insures that the Nexus® meter is optimized to download data as quickly as possible.
- Utilizing a novel Modbus TCP approach, the meter will download up to 20 times faster than existing Nexus® 125X Series meters. No long wait time to retrieve data.



Internal I/O

Relay Outputs

6RO1: 6 Relay Outputs Card

- 5 amps/125 volts AC/DC rated
- Form C (Latching)

Pulse Outputs

485P: Dual RS485/Pulse Output Card

- 4 KYZ Pulses
- Pulse width: 5 msec
- Relay type: Solid State
- Dual RS485 Ports

Input Status

16DI1: 16 Status Inputs card

- Used for alarm detect or pulse accumulation
- Up 150 volts DC wetted or non-wetted (24 volt DC nominal provided)

Note: The Nexus® 1500 meter provides one I/O slot for the 485P (Slot 1), and two I/O slots for the 6RO1 and 16DI1 (Slots 3 and 4).

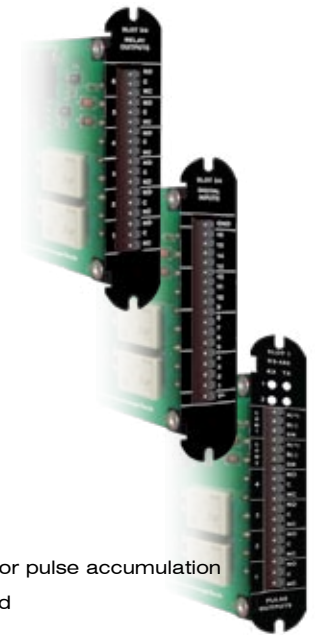

External I/O



EXTERNAL OUTPUT MODULES

Analog Outputs

- 1mAON4/1mAON8: 4 or 8 Analog Outputs, 0-1mA, self-powered, scalable, bidirectional
- 20mAON4/20mAON8: 4 or 8 Analog Outputs, 4-20mA, self-powered, scalable

Wiring: Common Mode

Accuracy: 0.1% of Full Scale

Calibration: Self-calibrating

Scaling: Programmable

Ordering: Up to 4 Analog Output modules for each Nexus® 1500 meter.

Digital Dry Contact Relay Outputs:

- 4RO1: 4 Relay Outputs, 5 amps, 125 AC/DC, Form C – Latching Relays
- Ordering: 1 module in addition to internal modules.

Digital Solid State Pulse Outputs:

- 4PO1: 4 Solid State Pulse Outputs, Form A or C KYZ pulses
- Maximum Pulse Speed: 20 pulses per second
- Ordering: Up to 4 modules per meter.

Output Module Accessories (Required):

- PSIO: Required for using an Output module and must be ordered with the module. The Nexus® 1500 does not have internal power for Output modules.
- MBIO: Mounting bracket for Output modules. Must be ordered with Output module.

Dimensional Drawings

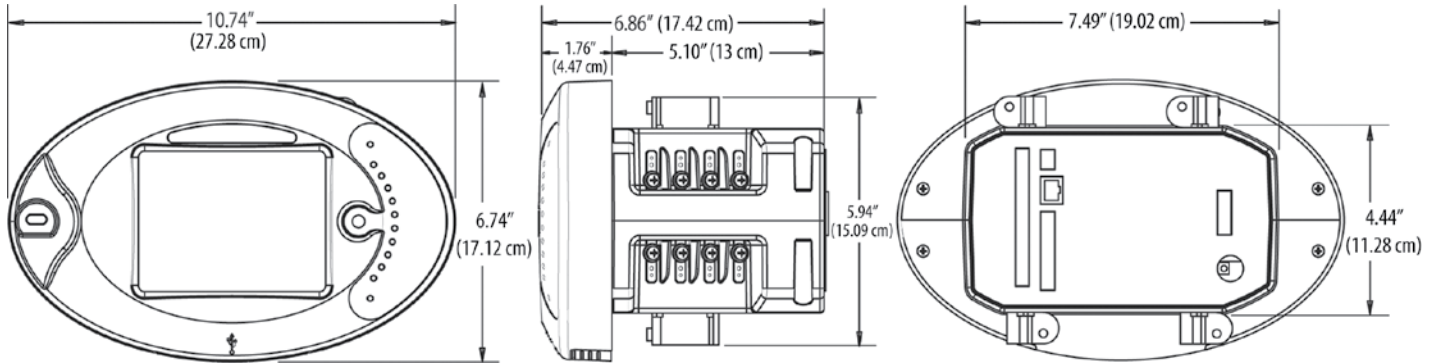

Wiring Diagrams

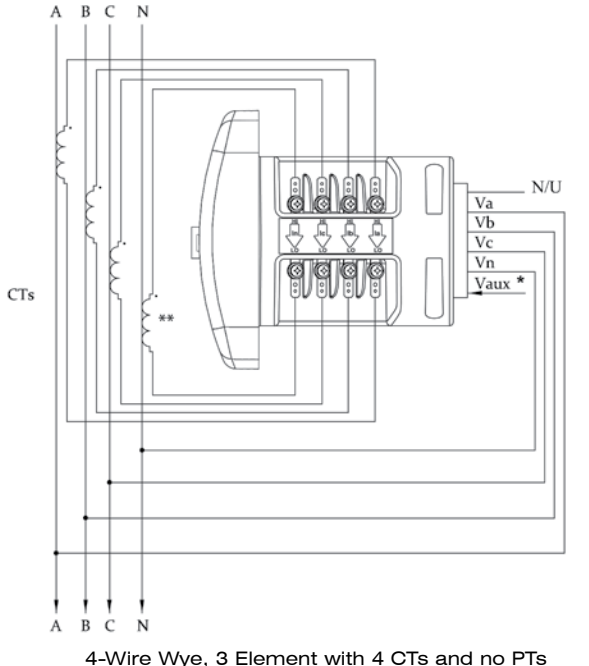
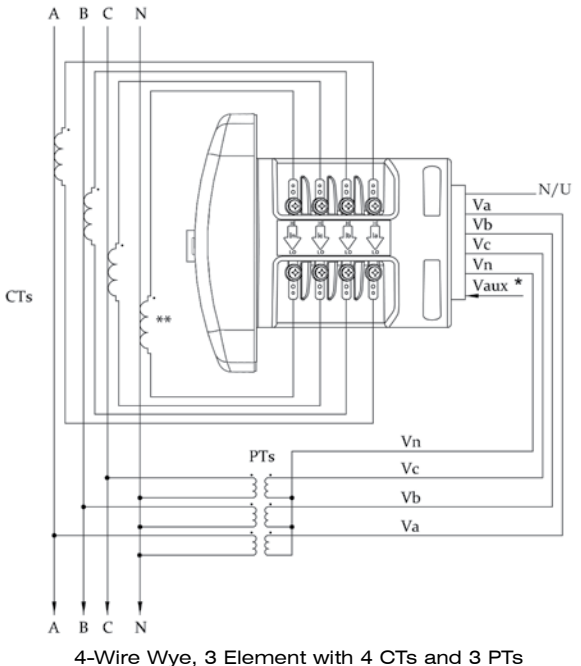
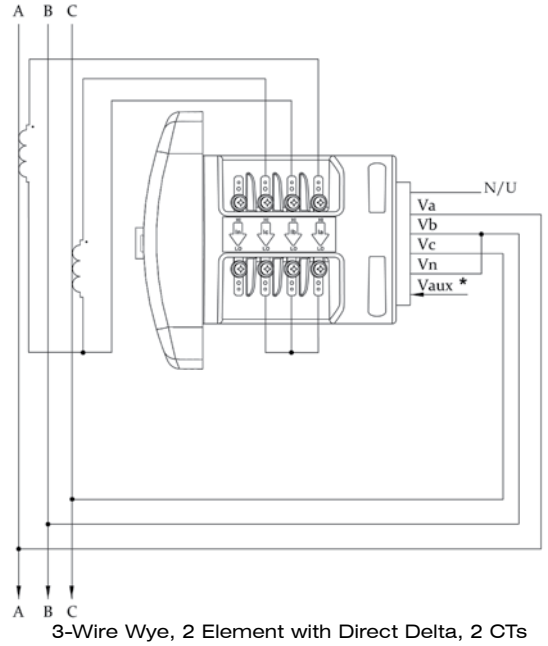
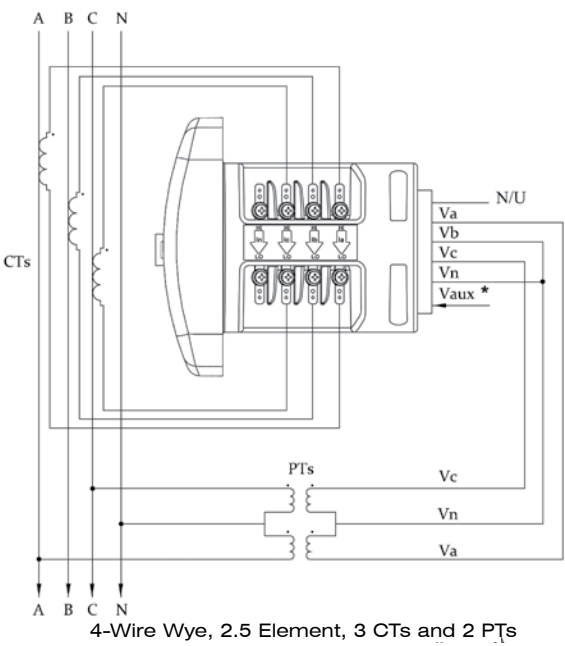

Vibrant Color LCD Touch Screen Display

Bright and Easy To Read

The Nexus® 1500 meter features an LCD color display with touch screen capability. The display uses bright TFT glass with a high temperature and long life LED backlight. LED is superior to CCFL solutions due to better temperature and half-life specifications. Screen displays include:

- Real-time viewing (voltage, current, power, demand)
- Accumulated energy and time of use readings
- Flicker readings
- Alarms
- Phasor analysis
- Harmonic spectrum analysis and waveforms
- Real time trending
- Log status
- Configuration settings



VIVID COLOR DISPLAY

Specifications

Input Voltage Range

- (5-347)VAC, Line to Neutral
- (10-600)VAC, Line to Line

Voltage Input Withstand Capability

- Voltage Inputs isolated to 2500VAC
Meets ANSI C37.90.1 (Surge Withstand Capability)

Input Current Range

- 5 Amp Inputs 4x continuous programmable to any CT range
- Fault Current recording to 80 Amps peak secondary based on 5 Amp full scale

Current Input Withstand Capability

- 100 Amps for 10 Seconds
- 300 Amps for 1 Second

Burden

- Voltage Inputs: 0.072W/Phase Max at 600 Volts, 0.003W/Phase Max at 120 Volts
- Current Inputs: 0.008VA per Phase Max at 20 Amps

Isolation

All inputs to outputs are isolated to 2500 VAC.

Temperature Rating

- Operating Temperature: (-20 to +70)°C
- Humidity: Up to 95% RH Non-condensing
- Storage Temperature: (-30 to +80)°C

Sensing Method

- Up to 1024 Samples per Cycle (Programmable)
- Voltage Transient: 10MHz ± 1.8kV ± 10%
- 16 Bit A/D Resolution – Multiple Converters
- Utilizes patented Accu-measure™ Technology
- True RMS

Accuracy Rating

- This unit complies with and exceeds ANSI C12.20 and IEC687 accuracy requirements.

Update Time

- 1 Second — Revenue Accurate Readings
- 200 msec — High Speed Readings

Control Power Requirements

- (Suffix -D2): (90–265)VAC, (100-370)VDC
- Burden: 25VA Max

Frequency Range

- 45Hz–69.9Hz

Communication Format

- Programmable parity and stop bits
- Communication Protocols: Modbus TCP/IP, ASCII/RTU, DNP 3.0
- ANSI Optical Port
- USB 1.1/2.0 Virtual COM Port
- RJ-45 Ethernet Port 10/100BaseT
- 2 RS485 Ports (optional)

Shipping

Total shipping weight:
approx. 5 lbs (2.3 kgs)

Shipping container dimensions: 16" x 13" x 11"
(40.64cm x 33.02cm x 27.94cm)

Compliance

- ANSI C12.20 Class 0.2 and IEC687* (Accuracy)
- ANSI C62.41 (Burst)
- ANSI/IEEE C37.90.1 – Surge Withstand
- IEC 1000-4-2 – ESD
- IEC 1000-4-3 – Radiated Immunity
- IEC 1000-4-4 – Fast Transient
- IEC 1000-4-5 – Surge Immunity
- EN61000-4-15 – Flicker Meter
- EN61000-4-7 – Harmonics
- EN61000-4-30 – Class A*
- CE Marked
- UL and cUL Listed

* Contact factory for specifics on compliance levels and applicable standards.

EXTERNAL OUTPUT MODULES

- 1mAON4** 4 Analog Outputs, 0–1mA
- 1mAON8** 8 Analog Outputs, 0–1mA
- 20mAON4** 4 Analog Outputs, 4–20mA
- 20mAON8** 8 Analog Outputs, 4–20mA
- 4RO1** 4 Relay Outputs
- 4PO1** 4 Solid State Pulse Outputs
- PSIO** Power Supply for Additional Output modules (must be ordered with external module)
- MBIO** Output Mounting Bracket (must be ordered with external module)

Ordering Information

To order a Nexus® 1500 meter:

1. Fill out the options you want in the order chart shown below. List accessories separately.
2. Specify Communicator EXT 3.0.
3. EIG can also provide current and potential transformers.
4. Email or fax order information and quantity to the fax number or email listed at the bottom of this page.

Ordering Specifications

	Nexus® Base Meter	Control Power	Frequency Range	Virtual Switch	Communication Expansion / Slot 1	I/O Slot 2	I/O Slot 3	I/O Slot 4
Option Numbers:	-	-	-	-	-	-	-	-
Example:	Nexus®1500	D2	60 Hz	V2	485P	NTRJ	6R01	6R01
	Nexus® 1500 Meter	115AC (100-240)VAC	60 Hz	V1 Standard Nexus® 1500 meter 128 MB memory / 512 s/c	X No Option	X No Option	X No Option	X No Option
		D2 Universal (90-265)VAC @50/60Hz or (100-370)VDC	50 Hz	V2 V1 + 1 GB memory / 1024 s/c	485P 2 RS485 and 4 Pulse Outputs	NTRJ Second RJ45 Network Card	6R01 6 Relay Outputs	6R01 6 Relay Outputs
				V3 V2 + 10 MHz Transient Recording		NTFO Second Fiber Network Card (ST Terminated)	16D11 16 Status Inputs	16D11 16 Status Inputs

Accessory Options

SOFTWARE

COMEXT3.1C

Communicator EXT 3.0
for Windows ®
Single-Computer License
(One Site)

COMEXT3.MC

Communicator EXT 3.0
for Windows ®
Multiple-Computer License
(One Site)

OUTPUT MODULES

1mAON4

4 Analog Outputs, 0-1mA

1mAON8

8 Analog Outputs, 0-1mA

20mAON4

4 Analog Outputs, 4-20mA

20mAON8

8 Analog Outputs, 4-20mA

4RO1

4 Relay Outputs

4PO1

4 Solid State Pulse Outputs

PSIO

Power Supply for External
Output modules
(must be ordered with
an external module)

MBIO

Output Mounting Bracket
(must be ordered with an
external module)

About Electro Industries: Electro Industries/GaugeTech is one of the oldest and largest manufacturers of microprocessor-based digital power meters in the United States. EIG's success is attributable to our willingness to support our users with on-staff technical expertise. Contact us and we will assist you in solving your complex metering applications.