

Nexus 1262/1272

Accu-Measure™
Auto-Calibrating
Metrology

High Performance Utility Billing Meters

With Communication & Advanced Power Quality



Nexus 1272
Performance Meter with
Advanced Power Quality
& Communication

Nexus 1262
Economical Meter with
Advanced Communication

INDUSTRIAL CUSTOMERS
UTILITY TIE LINES
POWER GENERATION

- 0.06% Watt/Hr Revenue Meter
- Auto-Calibrating Metrology
- Multi-Point CT & PT and Loss Compensation
- Advanced Power Quality Recording
- Eight Totalizing Registers
- Data Logging & Event Recording
- Unique Powerful Display Configurator
- Multiple Communication Paths
- Combination Modem & Ethernet

New! Total Web Solutions

WebExplorer WebReacher WebXML
WebAlarm WebMod WebDNP



XML Web Server
Email on Alarms
DNP 3.0 over Ethernet

**For Smart Grid and Intelligent
Substation Applications**

Accu-Measure Auto-Calibrating Metrology

The Nexus 1262/1272 meters are designed for demanding smart grid and intelligent substation applications. They provide one of the most profound analyses of electricity available in a socket meter. The units offer extensive advanced monitoring features to meet the most critical power monitoring requirements. Using advanced DSP technology, the Nexus' measure immediate and stored revenue power data coupled with superior power quality and communication. To meet the sophisticated standards required by utility companies and de-regulated power providers, the Nexus' basic package starts where most other meters end. Standard features in Nexus units provide the ability to meet advanced metering needs for the future.

ACCU-MEASURE™ AUTO-CALIBRATING METROLOGY

ElG's Accu-Measure™ Auto-Calibrating Metrology provides unmatched accuracy.

- Energy and Power Accuracy to Within 0.06%
- Auto-calibration over Time
- Automatic Temperature Drift Adjustments

4 QUADRANT MEASUREMENT

The unit is a full four quadrant meter and gathers hour data information in every quadrant.

- kWh Delivered and Received
- kVAh in Each Quadrant
- kVARh in Each Quadrant
- Q Hours

TIME OF USE

The 1262/1272 offers robust time of use functionality. Standard capabilities include:

- 8 TOU Schedules
- 4 Seasons/Year
- 20 Year Calendar
- Prior Month and Prior Season
- Programmable Freeze Registers

TRANSFORMER OR LINE LOSS COMPENSATION

Loss Compensation adjusts for both copper and iron losses with a simple user setup.

FIELD TEST MODE

- Test All Energy Readings
- Enable/Disable in Test Mode
- Preset Accumulators
- Freezable Accumulators

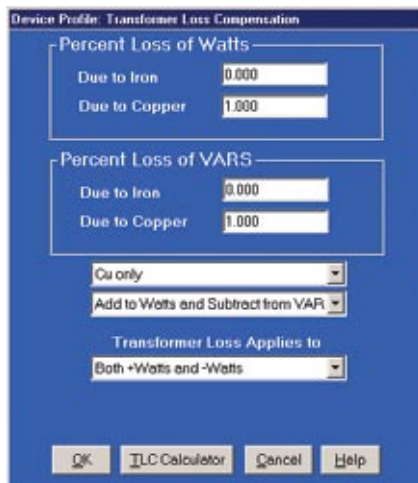

LOAD AGGREGATION/UNIVERSAL METERING

Using standard pulse inputs, the Nexus 1262/1272 can count pulses from external meters and accumulate usage. The pulse inputs can be used to totalize electrical usage and utility values, such as water or gas use data.

- 8 Pulse Inputs
- Individual Accumulating Registers
- 4 Totalizing Registers (Add or Subtract)

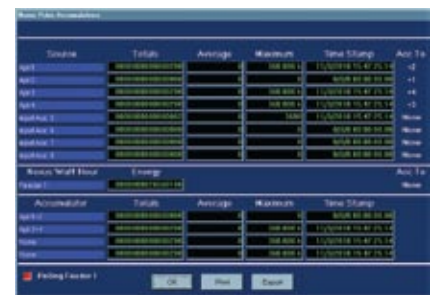

CT & PT COMPENSATION

The Nexus units compensate for errors in current transformers and potential transformers.

- Voltage Compensation
- Multipoint Current Compensation
- Multipoint Phase Angle Compensation
- Better than 0.01% Resolution



MULTIPLE DEMAND WINDOWS

The Nexus 1262/1272 simultaneously monitors five demand structures.

- Block Window Demand
- Rolling Window Demand
- Predictive Demand
- Thermal Demand
- Cumulative Demand
- Interval Length from 1 Second to Many Hours
- End of Interval Pulse Output
- End of Interval Pulse Input
- Cold Load Pickup

TIME STAMPED MAX. DEMANDS

The units gather demand information for all power values. Each value is date/time stamped.

- kW Demand, Delivered & Received, Max/Min
- kVAR Demand, Delivered & Received, Max/Min
- kVAR Coincident with kW Demand
- kVA Demand, Max/Min
- Amps Demand, Max/Min
- Voltage, Max/Min

Unique Display Configurator

The Nexus 1262/1272 is designed with one of the industry's most advanced LCD display configuration technologies. With this highly customizable display, choose from multitudes of pre-programmed display screens and create fully customized displays for any specific application. Build, from scratch, user display screens as needed that provide information on anything the meter measures (which is almost everything). Use the display to view not only electrical, but water or gas usage. Also use the meter as an aggregator for total usage. Provide ambient and transformer temperature or any other desired critical operational data on the display.

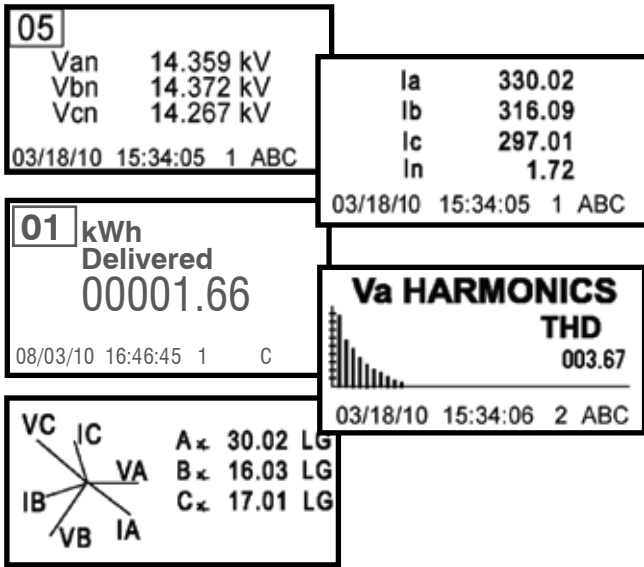

3 DISPLAY MODES/75 SCREEN SLOTS

The meter's memory has 75 slots for custom and/or pre-programmed screens. These slots can be allocated to any view mode with any number of slots used in each of the modes.

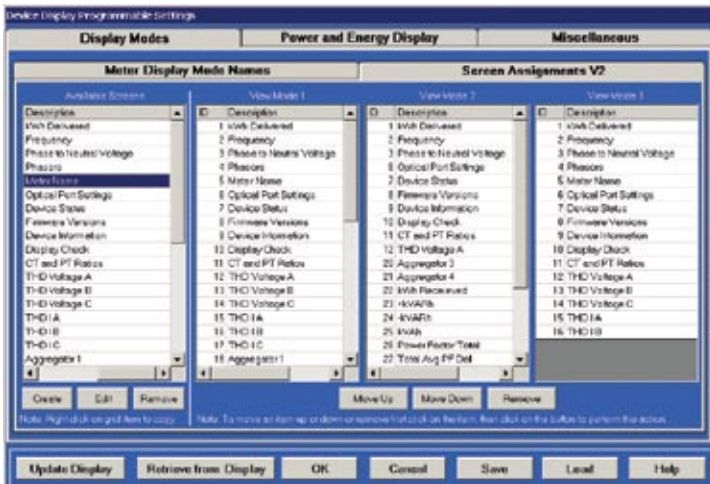

Highly configurable display assignments

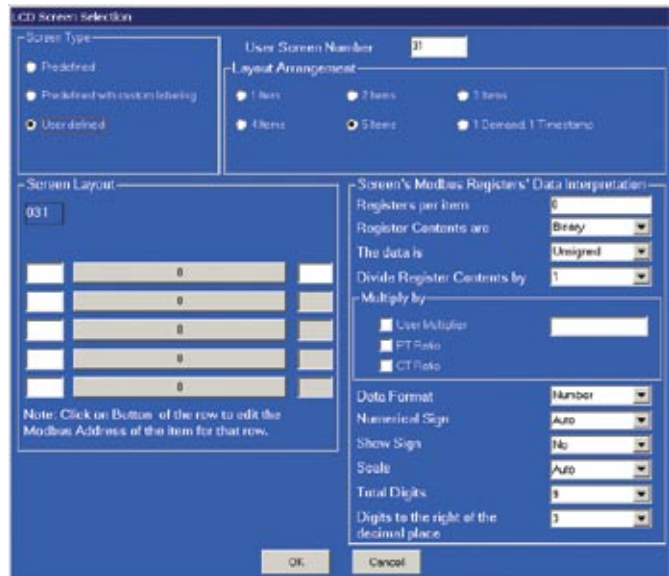

CUSTOM DISPLAY CONFIGURATOR TO CREATE EXACTLY WHAT'S NEEDED

- Make Custom Screens Based on Modbus Registers
- Make Any Custom Labels
- Customize Screen Numbering and Order
- Display Up To 5 Pieces of Information Per Screen
- Display Water, Gas and Other Types of Usage
- Add Diagnostic Information

NORMAL MODE

- kWh Delivered and Received
- kVAh Delivered and Received
- Peak Block Window Demand
- kVARh Delivered and Received
- Peak Rolling Window Demands

TIME OF USE MODE

- kWh and kW Demand Delivered and Received Total
- kVARh and kVAR Demand Delivered and Received for Each Register
- kVAh Delivered and Received for Each Register
- kVAh Delivered and Received Total

PRE-CONFIGURED DIAGNOSTIC SCREENS

Select from a large offering of diagnostic screens such as:

- Voltages
- Harmonic Magnitudes
- Meter Status
- Per Phase Amps
- Many More Diagnostic Screens Available
- Phase Angles
- Firmware Versions
- Phasor Diagram
- Watts/VARs

INFRARED TEST PULSE

The meter provides an infrared test pulse that can pulse for +Watt-Hour, -Watt-Hour, +VAR-Hour, -VAR-Hour and VA-Hour. This pulse uses a time modulated pulse integration, allowing the pulse to be accurate during short duration pulse tests using industry accepted reference standards.

STANDARD MULTI-PORT COMMUNICATIONS

- Optical Port
- 2 RS485 Serial Ports
- Modbus RTU/ASCII
- DNP 3.0
- Speeds Up to 115k bps

OPTIONAL COMMUNICATIONS

- Dial-Out modem (56k) with Battery Backed Outage Reporting
- Ethernet 100BaseT
- Ethernet/Modem combo

COMBINATION MODEM & WEB SOLUTION

This option allows you to access the meter through the web and through a modem for dial-up communication. Features include:

- 56k Modem
- 10/100BaseT Ethernet
- Total Web Solutions (Web Server)
- Email on Alarm
- Does Not Support Battery for Outage Reporting

STANDARD I/O

- IRIG-B 1 msec Time Synchronization to GPS Satellite Clock
- 4 Internal KYZ Pulse Outputs
- 8 KYZ Pulse/Status Inputs

OPTIONAL EXTERNAL I/O

Connect multiple external I/O Modules for enhanced I/O capability.

- Analog Outputs
- Analog Inputs
- Digital Status Inputs
- KYZ Outputs
- Relay/Alarm Outputs

CONTROL CAPABILITIES

- ElectroLogic™ Provides User-definable Control Outputs
- Action and/or Alarm on Abnormal Condition
- Action on Boolean Logic Combinations of Inputs or Electrical Conditions

DNP 3.0 LEVEL 2 PLUS

The Nexus 1262/1272 provides the industry's most advanced DNP 3.0 protocol implementations. DNP 3.0 is available on the serial and Ethernet ports. EIG's Nexus 1262/1272 complies with all DNP Level 1 and Level 2 certification requirements PLUS a host of additional features including:

- **Up to 136 Measurements:**
64 Binary Inputs, 8 Binary Counters, 64 Analog Inputs Mapped to DNP Static Points in the Customizable DNP Point Map
- **Up to 16 Relays and 8 Resets** Can Be Controlled through DNP
- **Report-By-Exception Processing** (DNP Events) Deadbands Can Be Set on a Per-point Basis
- **250 Events in Combinations of Four Events:** Binary Input Change, Frozen Counter, Counter Change, Analog Change
- **Freeze Commands:** Freeze, Freeze/No-Ack, Freeze with Time, Freeze with Time/No-Ack, scheduled Freeze Command
- **Freeze with Time Command:** Enables the Nexus Meter to Have Internal Time-driven Frozen Counter and Frozen Counter Event data
- Third Party Certification is Available

Total Web Solutions— Providing Advanced Metering Data Integration With the Web

Total Web Solutions is an advanced Ethernet communication architecture allowing you to design custom webpages, display metering data and host your meter power information website directly on a Nexus meter. The Nexus meter directly hosts the web data without any need for dedicated server software, ActiveX Controls or Java Applets. The meter does the data collection, the formatting and the page hosting.

ADVANCED FEATURES INCLUDE:

- Fully Customizable Webpage Development
- Direct Webpage Hosting With Live Readings
- Multiple Meter Hosting
- Read Direct From Meters (No Server Software Needed)
- No Active Controls or Java Downloads
- IT Dept Friendly. Works Through Firewalls; Low-Cost/High Functionality
- Instant Alarm Emails – Direct from the Meter

WEBEXPLORER

(Directly Host Metering Data)

EIG's WebExplorer provides you with direct access to all power data through Internet Explorer in standard HTML format, without needing to download ActiveX controls or Java applets. WebExplorer is fully programmable, so you can customize your own SCADA quality webpages, graphics and configurations.

- Easily Incorporated Into Any Existing Web Applications
- Fully Programmable Webpage Generator
- Brings in Direct XML Links, Displaying Many Meters on One Page

WEBXML

Creates Real Time Data in XML Format. WebXML allows the Nexus meter to gather data from the Nexus Host or through other meters and put the data directly into an XML format. This allows you to share data through the web with multiple applications and create custom webpages, using WebExplorer.



WEBALARM – EMAIL ALERTS

EIG’s WebAlarm sends real time email alerts via the Internet to up to 9 recipients simultaneously for any combination of event notifications.



- Real Time Alerts
- Simultaneous Emails to Multiple Recipients
- Update Users on Virtually Any Abnormality
- Uses Standard SMTP — Just Assign Email Addresses
- Shows the Last 10 Emails on Website for Later Investigation

WEBDNP

Using this feature, you can gain access to the meter speaking native DNP over Ethernet. This allows the unit to open an exclusive network socket for DNP 3.0. Using this unique technology, all other meter web

features are available simultaneously. Even with DNP 3.0 over the Ethernet, you still have access to multiple Modbus sockets, email alarms, web servers and many other communication features.

WEBMOD

(Open Architecture 3rd Party Integration)

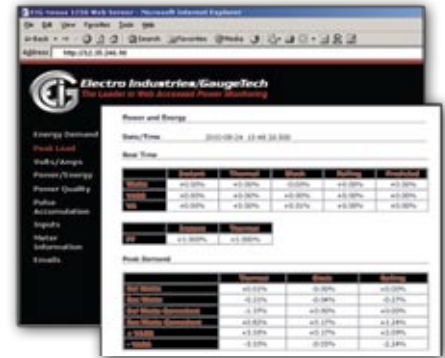

The 10/100BaseT design allows the unit to speak with 12 simultaneous sockets of Modbus TCP. EIG’s WebMod features Modbus TCP open protocol that can be easily integrated with most other software or hardware. And, with the built-in Modbus data concentrator, you can poll up to 8 devices or 512 unique polling items from any device that can speak Modbus RTU and/or Modbus TCP protocols.

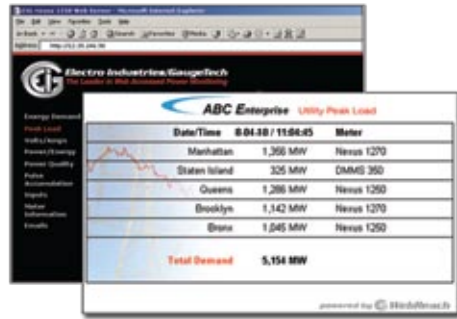

WebXML technology is easy to configure and extremely flexible. With WebXML, your data is instantly available to a host of software applications including Internet Explorer, Excel, Power Point and Word.

- Automatically Process and Present Data In Readable XML Format
- Add Scale Factors, Multipliers or Other Desired HTML Capability
- Display Data From Host Meter and/or Any Other Meter Using Modbus RTU or TCP/IP (WebReacher)
- Customized Programming
- Easily Viewed By Different Applications
- Modbus Data Concentrator

WEBREACHER

With EIG’s exclusive WebReacher technology, you can now access remote meters around the



world, retrieve data and consolidate it onto one webpage or website without any separate software SCADA package or client-side ActiveX controls or Java applets.

- No Additional Software Application Costs
- No Server System Required
- No Complex Integration
- No Costly Point Charges (Up to 32 Devices)

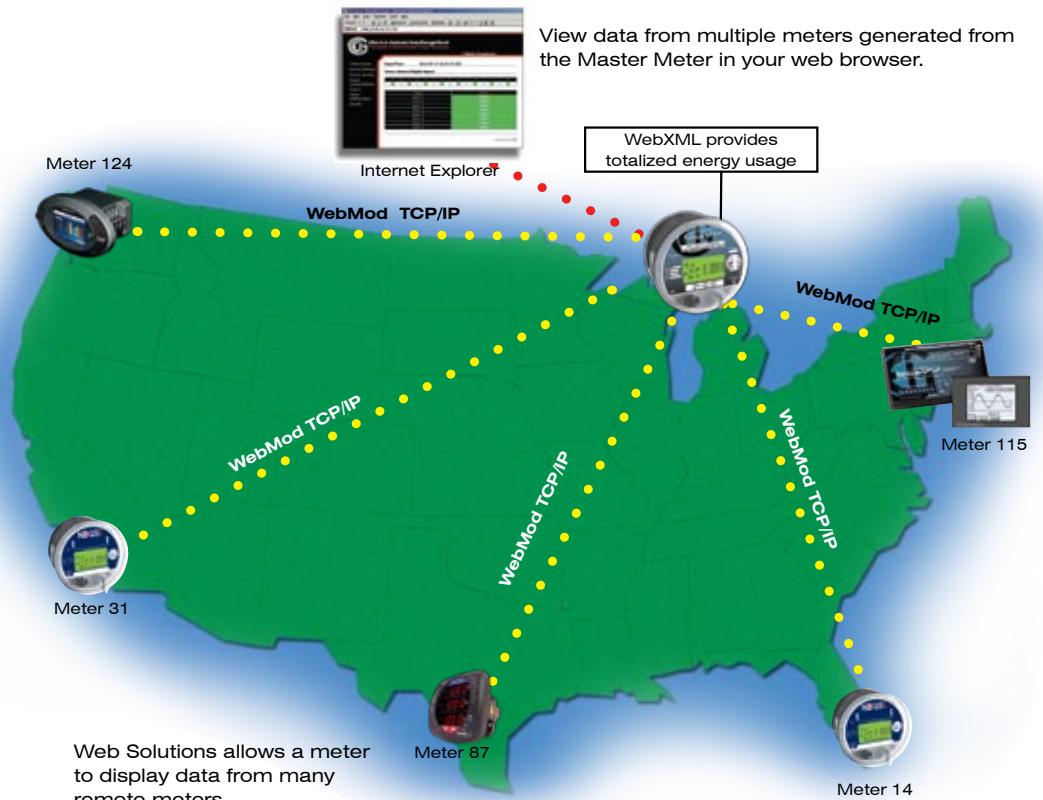

Nexus 1272 Advanced Power Quality Analysis Pinpoints Electrical Reliability Issues

The processing capability and accuracy of the Nexus 1272 makes it possible to gather power quality information with unmatched precision. The Nexus 1272 is ideally suited for application on all critical loads. From health care to micro-electronics, the 1272 has what it takes to capture every anomaly. This insures that when there is a power problem, you have the information required to act. All Power Quality logs are time stamped to the nearest millisecond to insure accurate recording. Nexus' Advanced Download Logic collects only new data to minimize download times.

EVENT/OUT OF LIMIT LOG

- Records 1024 Events
- Out of Limit Recording
- High-Speed Input Event Recording
- Outage Detection
- Extensive Limit Setting Capabilities with Multiple Limits per Selected Quantity

WAVEFORM LOG

The waveform recording capability of the Nexus is unparalleled by any meter. Waveform records of this quality have historically been reserved only for transmission lines. The power of the Nexus 1272 now makes this quality available to your critical customers.

- Extraordinary Resolution through 16 bit A/D Input
- Sample Rates from 16 to 512 Samples per Cycle
- Total Recording Times over 100 Seconds
- Up to Six Channels
- Voltage and Current Triggers
- External Event Trigger
- Voltage Surge/Sag Recording
- Current Fault Analysis

HARMONIC DISTORTION ANALYSIS

- Log Harmonics into Historical Log for Later Analysis
- Recorded Waveforms Provide Harmonics to the 255th Order
- View Waveform Record

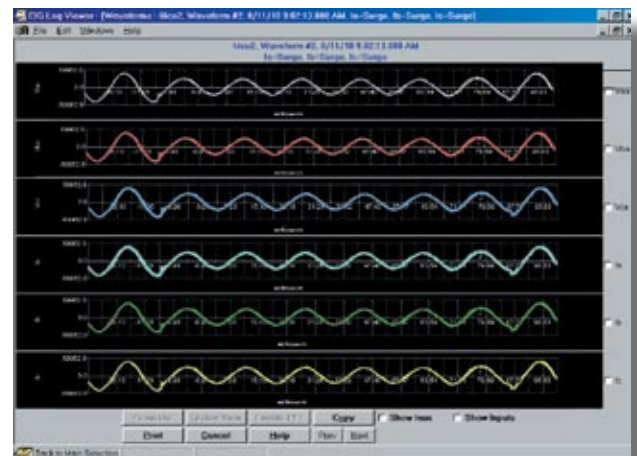
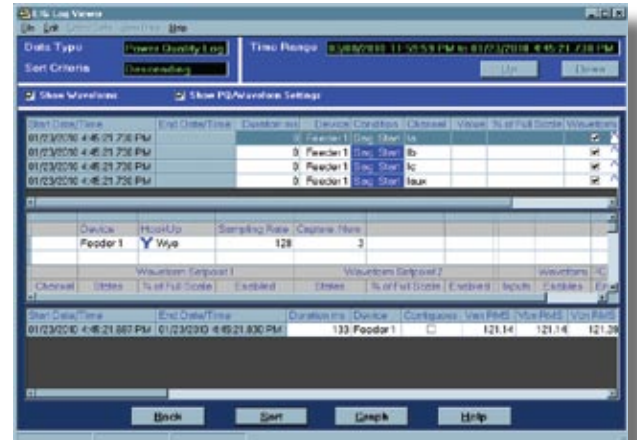

CBEMA/ITIC LOG

The separate CBEMA/ITIC Log captures all voltage transients that fall outside these standards. The onboard log holds 1024 events. The data is downloaded to a separate log in the meter database for easy analysis. See all voltage disturbances on one screen through the Communicator EXT software.

- Sag/Swell Analysis
- Transient Recording

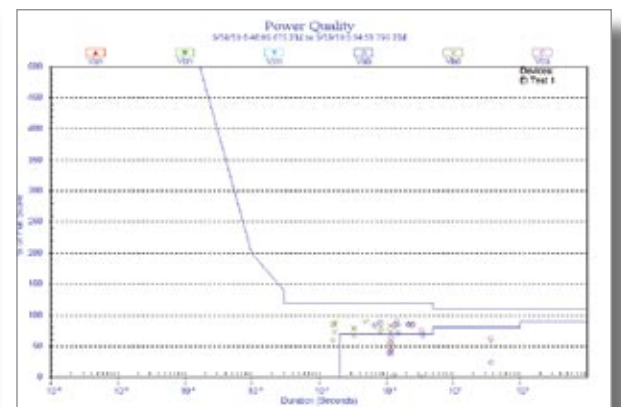

The accuracy and precision of the Nexus 1272 coupled with its extraordinary logging capability makes it an ideal tool for system performance and reliability analysis. For the first time, users have the accuracy and precision of a digital fault recorder at the revenue-metering site without the expense. The Nexus' 16-bit accuracy and resolution for waveform records actually exceeds many digital fault recorder products. Combine the Nexus 1272 with EIG's suite of software solutions to further expand the level of understanding during any monitoring situation.

AiREPORTS – PQ ANALYSIS

AiReports provides automated analysis and reports (1272 Only) for abnormal events.

- Uses Artificial Intelligence
- Evaluates All Data from Nexus Monitor
- Rates Events for Severity
- Identifies Probable Causes
- Identifies Possible Impacts
- Recommends Corrective Actions or Solutions
- Prepares and Formats Report of All Power Quality Events
- PQDIF File Format Converter Allows Nexus Data to be Read by Standard EPRI Power Quality Viewing Software.
- COMTRADE File Converter Changes Fault Records to Standard Fault Analysis File Formats

COMMUNICATOR EXT FAULT ANALYSIS

- Compares Multiple Fault Records
- Measures Waveform Traces
- Inserts Timing Marks to Analyze Waveform Transients
- Views CBEMA Logs

AT THE INTERCHANGE POINT

Nexus gives you the power of a sequence of events recorder on every transmission line or interchange point. Nexus is always watching and has extended memory capability, which can record multiple faults, or even frequency swings, during stability problems. Capture all voltages and currents.



Download the data and open the files with Communicator EXT. Compare multiple channels. Measure amplitudes and timing with millisecond resolution. See system reliability events that lasted for several seconds.

TEST PROTECTIVE EQUIPMENT

Need to test protective equipment performance? Simply take the Nexus record and convert to COMTRADE format. Insert the file directly to protective test equipment to verify relay performance.

AT THE CUSTOMER

When that key customer calls, simply perform a download from the Nexus 1272. In a few minutes, all the data related to any event is on your desktop. A completed report is ready to review internally or email to the customer. Probable causes are identified and corrective actions recommended.

Need to perform a more detailed evaluation? Simply open the viewer to look at the waveforms and see exactly what happened to voltages and currents throughout the event. Only Nexus provides precise pictures for many seconds.

Supported Meter Forms

FORM	RATED VOLTAGE	HOOUP
9S	0 to 277V L-N	3E, 4W, Wye
36S	0 to 277V L-N	2½ E, 4W, Wye with Neutral
45S	0 to 480V L-L	2E, 3W, Delta
SWB2	0 to 277V	Programmable (Universal Forms)
9A	0 to 277 L-N	A Base Form

Accuracy

PARAMETER	ACCURACY
Voltage	0.02%
Current	0.05%
Frequency	0.001Hz
kW	0.06%
kWh@1.0PF	0.06%
kWh@0.5PF	0.10%
kVAR	0.10%
kVA	0.10%
PF	0.10%

MULTIPLE MEMORY LOGS

Nexus meters provide many logs to record historical, alarm and system event data. These logs can be used for profiling, recording events and logging electrical power parameters over time. Additionally, using the advanced I/O available with the product, you can also log process measurements, including temperature, pressure, flow, etc.

TWO HISTORICAL TREND LOGS

These logs allow you to trend virtually any electrical parameter over time. This includes all electrical and I/O parameters.

- Up To 64 Values per Log
- Programmable Trend Times
- Provides Magnitude and Duration of Event
- Millisecond Resolution
- 2 Separately Programmable Logs
- Separately Recorded Time Base
- Records Alarms For Electrical and I/O Channels

OUT OF LIMITS LOG

This log records all out-of-limit alarms, including the magnitude and the duration of the alarm.

SYSTEM EVENTS LOG

The unit records the following system events for security and anti-tampering.

- Power Up
- Power Down
- Password Access
- Password Modification
- Change of Programmable Settings
- Change of a Run Time
- Change of Clock Time by Communication (Modbus or DNP)
- Test Mode Usage
- Meter Resets (Logs, Max/Min, Energy)

INPUT STATUS LOG

This log records when a digital status change occurred in either the internal or external inputs.

- Status Log for External Events
- Internally Labeled to Define Events

CONTROL OUTPUT LOG

This log records the logic and state that triggered a control output. The graphical log shows all the steps that led up to the event.

- Displays Pre- and Post Analysis
- Internally Labeled to Define Events
- Advanced I/O Analysis

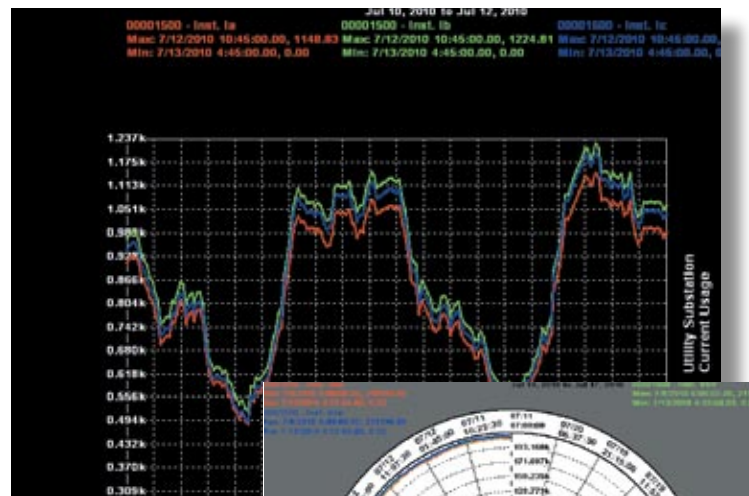

Historical Trending

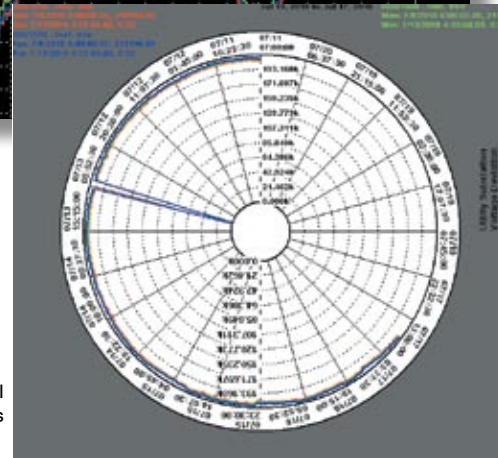

Replace Conventional Chart Recorders

Start Date/Time	End Date/Time	Duration (s)	Device Name	Module Name	Input Name	Status	Stat
3/24/2010 3:21:00.990 PM	3/24/2010 3:21:01.170 PM	180	MyNexusMeter_Caes	HIS Inpt. Input	HIS Input 1	0	DK1
3/24/2010 3:21:00.290 PM	3/24/2010 3:21:00.000 PM	690	MyNexusMeter_Caes	HIS Inpt. Input	HIS Input 1	0	DK1
3/24/2010 3:20:58.250 PM	3/24/2010 3:20:59.310 PM	60	MyNexusMeter_Caes	HIS Inpt. Input	HIS Input 1	0	DK1
3/24/2010 3:19:51.500 PM	3/24/2010 3:19:51.700 PM	230	MyNexusMeter_Caes	HIS Inpt. Input	HIS Input 1	0	DK1
3/24/2010 3:19:51.070 PM	3/24/2010 3:19:51.340 PM	300	MyNexusMeter_Caes	HIS Inpt. Input	HIS Input 1	0	DK1
3/24/2010 3:19:48.900 PM	3/24/2010 3:19:50.230 PM	1250	MyNexusMeter_Caes	HIS Inpt. Input	HIS Input 1	0	DK1
3/24/2010 3:19:48.300 PM	3/24/2010 3:19:48.540 PM	240	MyNexusMeter_Caes	HIS Inpt. Input	HIS Input 1	0	DK1
3/24/2010 3:19:47.620 PM	3/24/2010 3:19:48.300 PM	580	MyNexusMeter_Caes	HIS Inpt. Input	HIS Input 1	0	DK1
3/24/2010 3:19:46.730 PM	3/24/2010 3:19:47.150 PM	440	MyNexusMeter_Caes	HIS Inpt. Input	HIS Input 1	0	DK1
3/24/2010 3:19:46.220 PM	3/24/2010 3:19:46.300 PM	110	MyNexusMeter_Caes	HIS Inpt. Input	HIS Input 1	0	DK1
3/24/2010 3:19:46.220 PM	3/24/2010 3:19:46.220 PM	0	MyNexusMeter_Caes	HIS Inpt. Input	HIS Input 8	1	Open
3/24/2010 3:19:46.220 PM	3/24/2010 3:19:46.220 PM	0	MyNexusMeter_Caes	HIS Inpt. Input	HIS Input 7	1	Open
3/24/2010 3:19:46.220 PM	3/24/2010 3:19:46.220 PM	0	MyNexusMeter_Caes	HIS Inpt. Input	HIS Input 6	1	Open
3/24/2010 3:19:46.220 PM	3/24/2010 3:19:46.220 PM	0	MyNexusMeter_Caes	HIS Inpt. Input	HIS Input 5	1	DK
3/24/2010 3:19:46.220 PM	3/24/2010 3:19:46.220 PM	0	MyNexusMeter_Caes	HIS Inpt. Input	HIS Input 4	1	Open
3/24/2010 3:19:46.220 PM	3/24/2010 3:19:46.220 PM	0	MyNexusMeter_Caes	HIS Inpt. Input	HIS Input 3	1	Open
3/24/2010 3:19:46.220 PM	3/24/2010 3:19:46.220 PM	0	MyNexusMeter_Caes	HIS Inpt. Input	HIS Input 2	1	Open
3/24/2010 3:10:06.780 PM	3/24/2010 3:10:07.870 PM	1090	MyNexusMeter_Caes	HIS Inpt. Input	HIS Input 1	0	DK1

View Alarms, Status Changes and Control Events

Logging Specifications

Model	Memory	Historical Log 1 ¹	Historical Log 2 ¹	CBEMA / ITIC ²	Out of Limit Log ²	Waveform Log ³	Output Log ²	Input Log ²	System Events ²
1272	Standard	85 Days	133 Days	512	1024	63	256	1024	1024
1272	Advanced	555 Days	133 Days	512	1024	95	256	1024	1024
1262	Standard	69 Days	32 Days	N/A	512	N/A	512	1024	1024
1262	Advanced	480 Days	133 Days	N/A	512	N/A	512	1024	1024

1 Assumes Logs store 4 scaled energy readings every 15 minutes

2 Number of Events Recorded (assumes 14 parameters monitored)

3 Number of Waveform Records. Each record may be from 8 to 64 cycles in duration depending upon meter setup

DIAL-OUT ON OUTAGE

The INP2 modem has a dial-out circuit with a battery that detects when voltage is lost and dials out to provide outage notification. Additionally, the circuit can be configured to dial out when many other circumstances occur. The Nexus 1262/1272 dials to the EIG Dial-In Server which allows users to be paged or emailed with notification of events. When the modem option card is installed, the meter also includes a gateway port. This allows the meter to act as a master for up to 7 additional meters and dial out on alarm for any of these meters.

DIAL-OUT FOR OTHER EVENTS

The meter will dial out for the following circumstances:

- Limits/Status Change
- High Speed Input Change
- Waveform Record Capture
- CBEMA Power Quality Event
- Control Output Change
- Control Output Change
- Cycling of Control Power
- Password Failure on a Call Coming into the Modem
- Meter Communication Failure

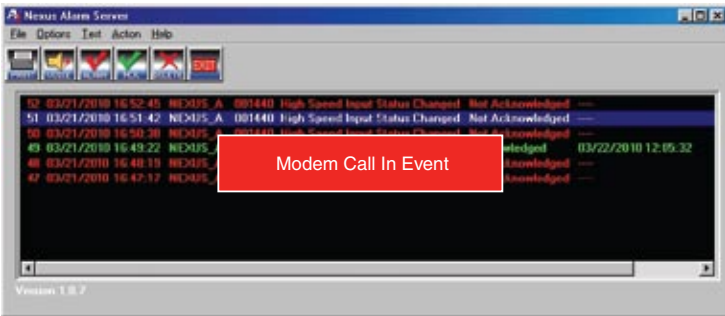
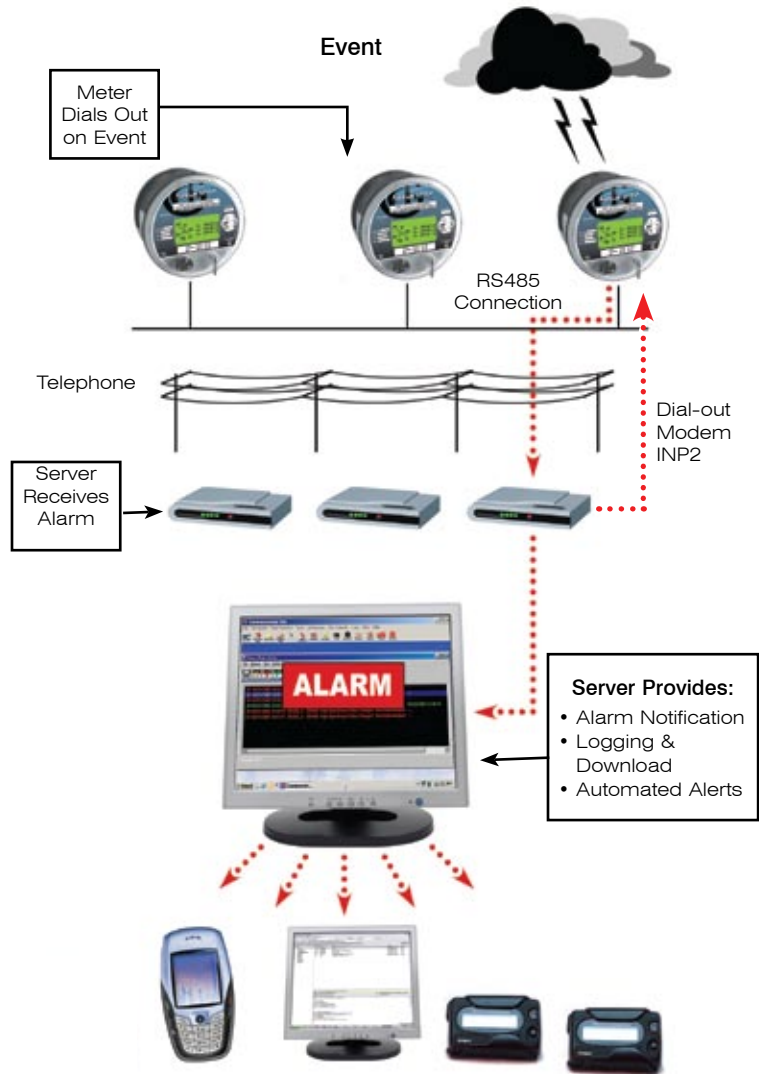

Visual Alarm

DIAL-IN SERVER CAPABILITIES

The EIG Dial-In Server will record all notifications, accept downloads from the meter and allows users to be notified by email and paging automatically. Features of the Dial-In Server include:

- Unlimited Meters
- Email Notification
- Audible System Alarm
- Scalable Multi-server Architecture
- Paging Notification

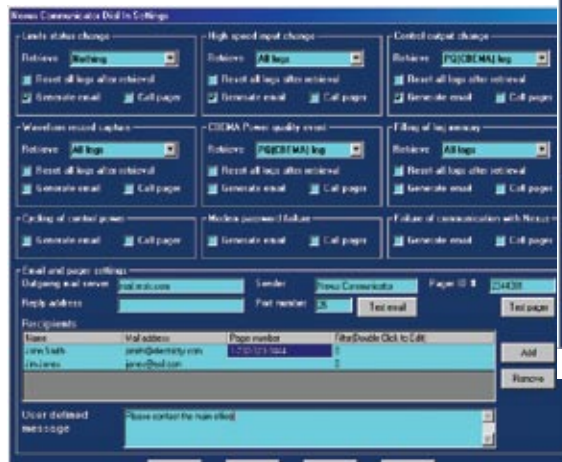

Dial-Out Logic

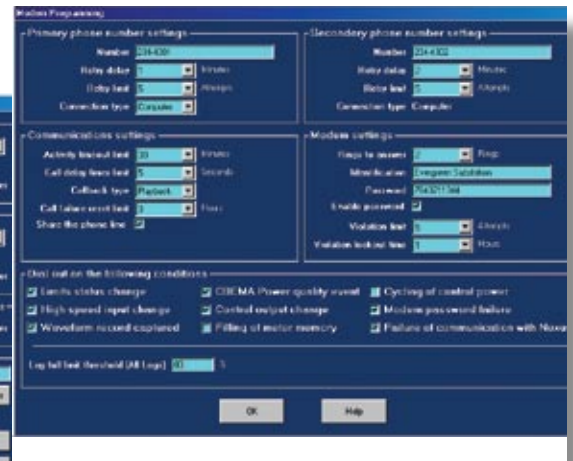

Dial-In Settings

Dimensions and Mounting

Nexus 1262/1272
Switchboard Case Front View

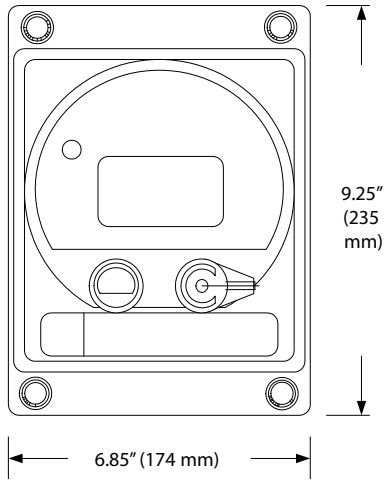

Nexus 1262/1272
Switchboard Case Back View

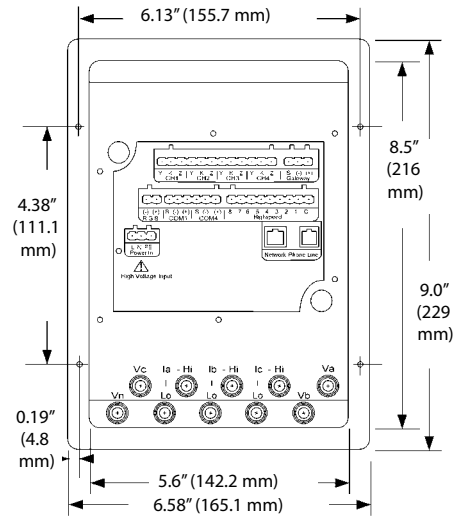

Nexus 1262/1272
Front View

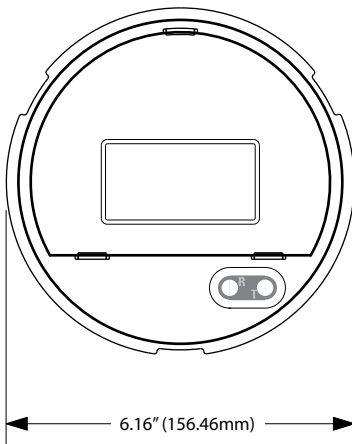

Nexus 1262/1272
Side View

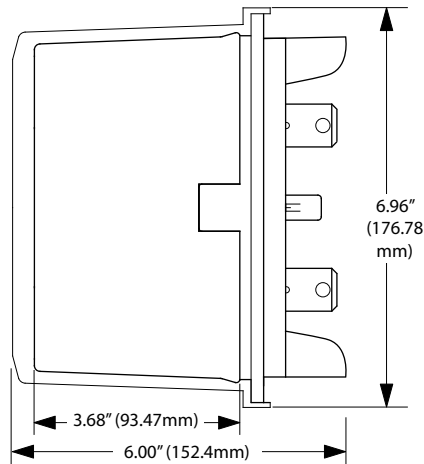

Nexus I/O Modules
Front View

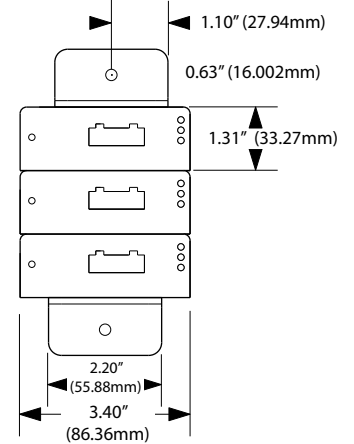

Nexus 1262/1272
A Base Front View

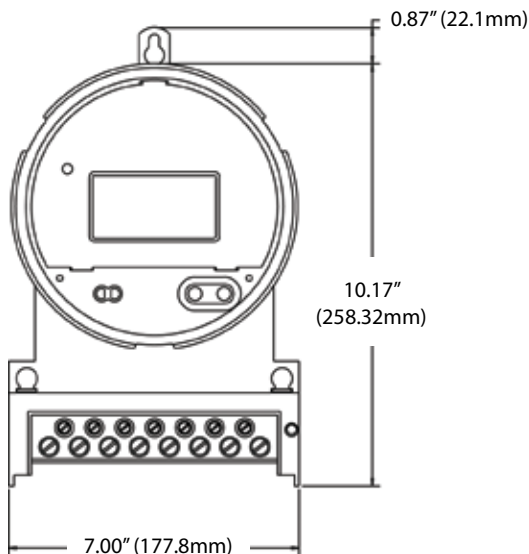

Nexus 1262/1272 A Base
Side View

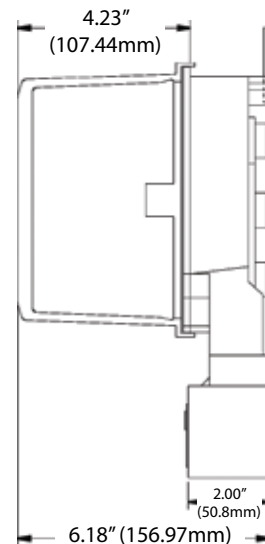

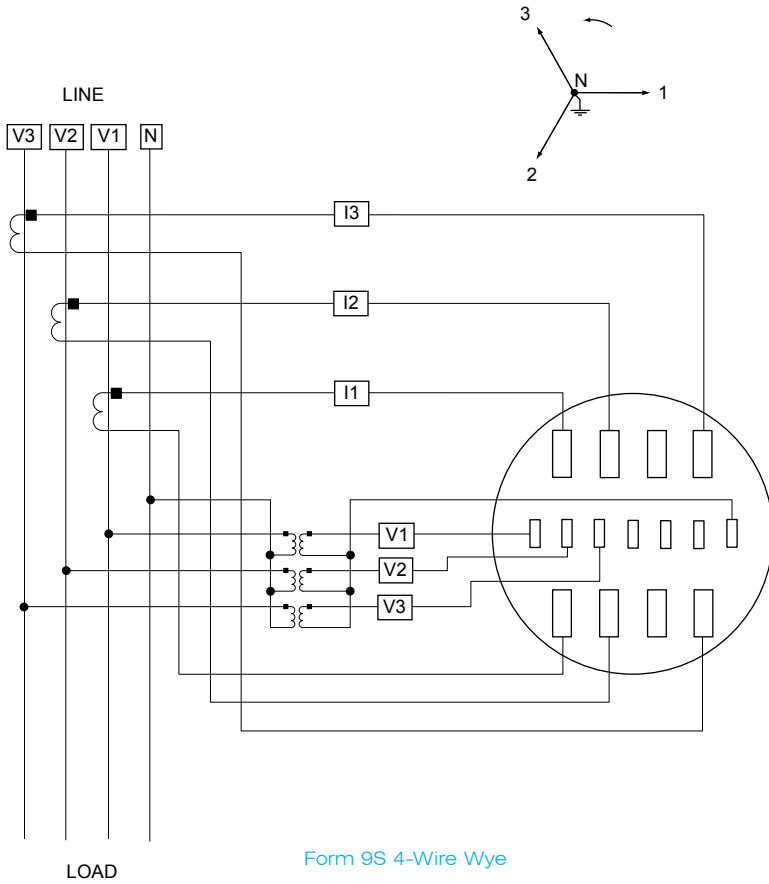

Switchboard Mount

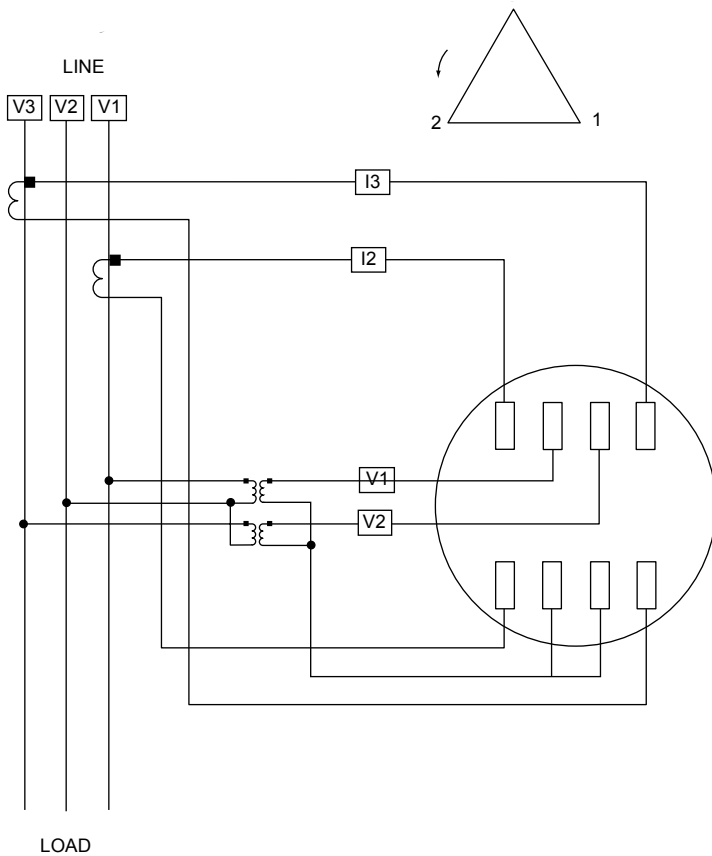
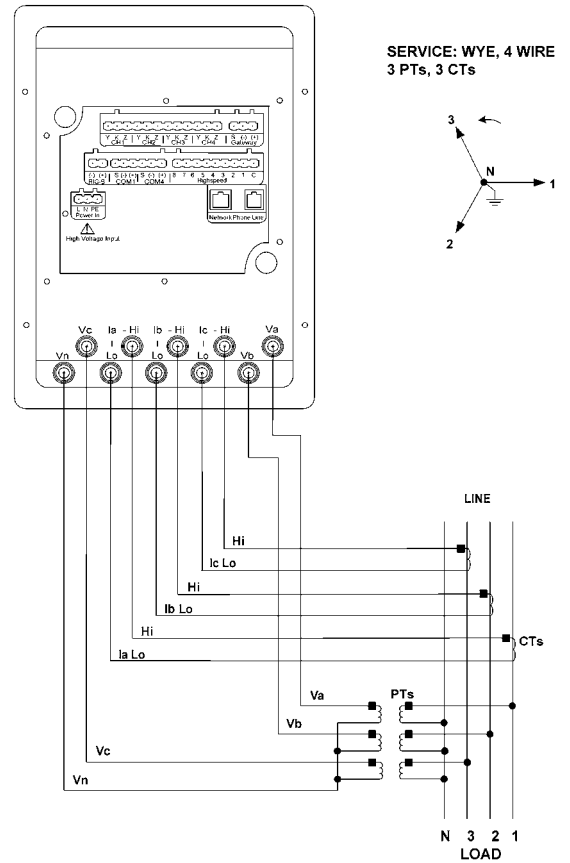

Switchboard Mount

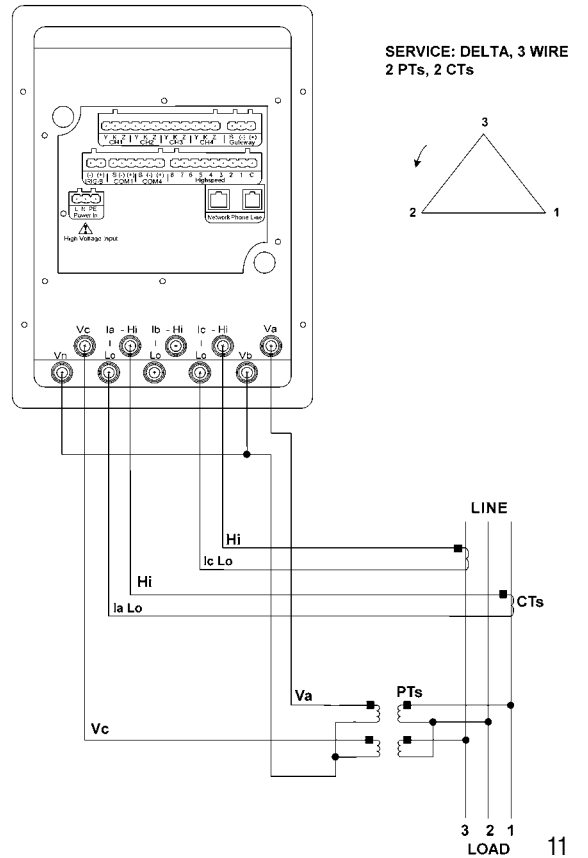

Specifications

SENSE INPUTS:

CURRENT (AC)

- Transformer (CT) rated
- 2 or 3 current inputs depending on Form (Ia, Ib, Ic)
- Class 2 – 1A nominal, burden 0.000312VA@2.5A
- Class 10, 20 – 5A nominal, burden 0.0125VA@25A
- 0.1% of nominal pickup current
- 120% over range of Meter Class
- 500% Overload for 1 second, non recurring

VOLTAGE (AC)

- Blade powered unit, standard voltage (option S): 480Vmax Phase to reference (Va, Vb, Vc to Vref). Burden total 12VAmax (including power supply) 600Vmax Phase to Phase (Va to Vb, Vb to Vc, Vc to Va)
- Blade powered unit low voltage (option LV): 69Vmax between Vref and Va, Vb, Vc inputs. Burden total 12VAmax (including power supply) 120Vmax between Va, Vb, Vc inputs
- Externally powered units (options SE, DE): 480Vmax between Vref and Va, Vb, Vc inputs. Burden 0.33VA@576V 600Vmax between Va, Vb, Vc inputs
- Input impedance 1Mohm/phase.
- 20% over range of rated voltage.
- 2V pickup voltage.

EXTERNAL POWER SUPPLY OPTIONS

- Standard external (option SE): (102 to 276)Vac @50/60Hz. 12VA max.
- Low voltage external (option DE): (18 to 60)Vdc. Burden 9W max.

- Separate power cord.
- Switchboard meter is always separately powered (option SE or DE).

ISOLATION

- All Inputs and Outputs Isolated to 2500 Volts
- Com Ports Isolated From Each Other to 1000 Volts

SENSING

- Accu-Measure™ Technology
- 16 bit A/D Inputs
- True RMS
- 8 Channel Sample & Hold

MEMORY

- All Meter Setup Parameters, Measurements & Logs Contained in Nonvolatile RAM

STANDARD COMMUNICATIONS

- LCD Display
- IR Port
- Two RS485 Serial Ports
- Modbus RTU, Modbus ASCII, DNP 3.0
- Data Speeds of up to 115k bps
- Eight High-Speed Input Channels

OPTIONAL COMMUNICATIONS

- 56K Modem with Dial-Out Capabilities
- Internal 10/100BaseT Rapid Response™ Ethernet
- Modem/Ethernet Combo Card
- Modbus TCP and DNP LAN/WAN

INTERNAL 8ch DIGITAL INPUTS

- Type: Self Excited, for Dry Contacts Only
- Internal Wetting Voltage: 12V DC Typical

INTERNAL 4ch SOLID STATE OUTPUTS (kyz)

- Type: Form A or C

- On Resistance: 23-35Ω
- Peak Voltage: 350V DC
- Continuous Load Current: 120mA
- Peak Load Current: 350mA (10ms)
- Off State Leakage Current @350V DC: 1: μA
- Opto Isolation: 3750V rms (60Hz, 1 min.)

CLOCK TIMING

- Internal Clock Crystal - Accuracy Better than 2 Minutes per Month
- IRIG-B Input for Synchronizing to External GPS Clock Signal - Accuracy Better than 1 msec per Month
- Line Sync - Accuracy Better than 1 Second per Month

ENVIRONMENTAL

- Operating Temperature: (-40 to +85)°C
- Display Temperature: (-20 to +60)°C
- Raintight Lexan Cover (Socket)
- Temperature Specifications to Indirect Light

SECURITY

- Hardware Lock Secures Meter Settings
- Two 10-Character Passwords
- One Password Controls Access to Read Meter Digitally
- Separate Password Controls Access to Program Meter
- Additional 8 level password sequence available by user configuration

SHIPPING

Weight:
 Socket: 10 Lbs Switchboard: 16 Lbs
 Dimensions:
 Socket: 13" x 10" x 11" Switchboard: 16" x 14" x 11"

APPROVALS

- IEC 60687 - KEMA Certified
- IEC 62053-22 - KEMA Certified
- California ISO
- NY State Public Service Commission
- USDA Technical Standards Committee Rural Development Unit
- Nmi - Brazil
- CEEE - Brazil
- Union Fenosa - Spain
- CAM - Endesa Chile
- Electric Power Test Research Institute of China - China Southern Power Grid
- China Northwestern Electric Power Research Institute
- NCEPRI - Beijing
- CEPRI - China State Grid
- ATS - Korea

COMPLIANCE STANDARDS

- ANSI C12.20 Accuracy
- ANSI/IEEE C37.90.1 Surge Withstand
- ANSI C62.41 Surge Immunity
- IEC 1000-4-2 ESD
- IEC 1000-4-3 Radiated Immunity
- IEC 1000-4-4 Fast Transient
- IEC 1000-4-5 Surge Immunity
- IEC 1000-4-6 Conducted Immunity
- IEC 60068-2-6 Vibration (Sinusoidal)
- IEC 60068-2-27 Shock Test
- IEC 695-2-1 Resistance to Heat & Fire
- IEC 68-2-1 Cold Test
- IEC 68-2-2 Dry Heat
- IEC 68-2-30 Damp Heat

Ordering Information (To order, please use this guide)

Option Numbers:	Model	Memory	Form	Class (Amps)	Frequency	Power Supply ¹	Optional Communication
Example:	1272	A	45S	20	50	DE	INP200
	1272	S Std	9S	2 Amps	50 50 Hz	S Std Blade Powered	X No Optional Com
	1262	A Adv	36S	10 Amps	60 60 Hz	SE Std Ext 102-270V AC/DC	INP2 Modem with Dial-Out
			45S	20 Amps		DE DC Ext 18-60VDC	INP200 10/100BaseT Ethernet
			SWB2 (Switchboard)			LV 69VAC Blade Powered	INP202 Modem & Ethernet Combo (No Dial-Out)
			9A (A Base)				

¹ Switchboard Meter Only Supports SE or DE Options.

Accessory Options

OPTIONAL I/O MODULES

- 1mAON4** 4 Analog Outputs, 0-1mA
- 1mAON8** 8 Analog Outputs, 0-1mA
- 20mAON4** 4 Analog Outputs, 4-20mA
- 20mAON8** 8 Analog Outputs, 4-20mA
- 4RO1** 4 Relay Outputs
- 4PO1** 4 Solid State Pulse Outputs
- 8AI1** +/- 0-1mA, 8 Analog Inputs
- 8AI2** +/- 0-20mA, 8 Analog Inputs
- 8AI3** +/- 0-5VDC, 8 Analog Inputs
- 8AI4** +/- 0-10VDC, 8 Analog Inputs
- 8DI1** 8 Status Inputs, Wet/Dry

POWER OPTIONS

- PSIO** I/O Power Supply (Required with I/O Module)
- BAT1** External Replaceable Battery for Dial Out on Outage

MOUNTING OPTIONS

- MBIO** I/O Module Mounting Bracket
Power Supply and Mounting Bracket
Required with any I/O Option

SOFTWARE OPTIONS

- COMEXT3.1C** Communicator EXT 3.0 for Windows® Single-Computer License (One Site)
- COMEXT3.MC** Communicator EXT 3.0 for Windows® Multiple-Computer License (One Site)
- AIEXT.1C** AiReports EXT Power Analysis Software for Windows® Single-Computer License (One Site)
- AIEXT.MC** Multiple-Computer License (One Site)
- DISEXT.1C** Dial-In Server Single-Computer License (One Site)
- DISEXT.MC** Dial-In Server Multi-Computer License (One Site)



Electro Industries/GaugeTech
 1800 Shames Drive • Westbury, NY 11590
 1-877-EIMETER (1-877-346-3837) • E-Mail: sales@electroind.com
 Tel: 516-334-0870 • Web Site: www.electroind.com • Fax: 516-338-4741