

Toxic gas hazards

OLCT 10



Toxic Gas Detectors

Designed for use in **boiler rooms and car parks**, the new **OLC(T) 10** range assures you of the most cost effective solution for the continuous monitoring of toxic gases and vapours in the ambient air. Shock-resistant, minimized size, easy to install and operate, the Oldham **OLC(T) 10** detectors combined for instance with the **MX 15** control unit meet the more demanding user requirements in accordance with the European standards.

Specifications

- Electrochemical Cells
- 4-20 mA analog output
- IP66
- Fast and accurate response
- ATEX Approval for use in hazardous areas
- Up to five sensors per channel



CE ATEX

	OLCT 10
Type	• Electrochemical cell sensor
Range	• 0-300 ppm CO / 0-100 ppm NO / 0-30 ppm NO ₂
Signal output	• Normal operation 4-20mA (Fault < 0,5 mA or > 23,2 mA)
Settings	• Without opening the enclosure by means of 2 potentiometers for zeroing and spanning • 2 mA signal output in maintenance mode • One dedicated connector to get a gas measurement
Power supply	• 15 to 30 VDC (nominal 24 VDC) 1 : I out (signal) 3 : +24 VDC
Consumption	• 30 mA max
Cabling	• 4 km when connected to an Oldham control unit (128 Ω max. in loop, core size 2 x 1,5 mm ²) • 2-wire, shielded, core size 0,75 to 1,5 mm ² • 2 cable glands M16 (outer diameter 4 to 8 mm)
Size (W x H x D)	• 118 x 157 x 60 mm
Material	• ABS
IP Rating	• IP66
Expected Lifetime	• Typical 24 to 48 months depending on the gas to detect
Operating Temperature	• -10 to + 45 °C
Operating Humidity Range	• 15 % RH to 90 % RH
Operating Pressure	• 80 to 120 kPa
Response Time	• NO ₂ : T90 < 60 s, NO : T90 < 120 s, CO : T50 < 15 s
Approvals	• Electromagnetic Compatibility EN 50270 • ATEX II 3 G / EEx nA II C T4

OLDHAM
Group

Gas detection / stack gas monitoring

Dimensions

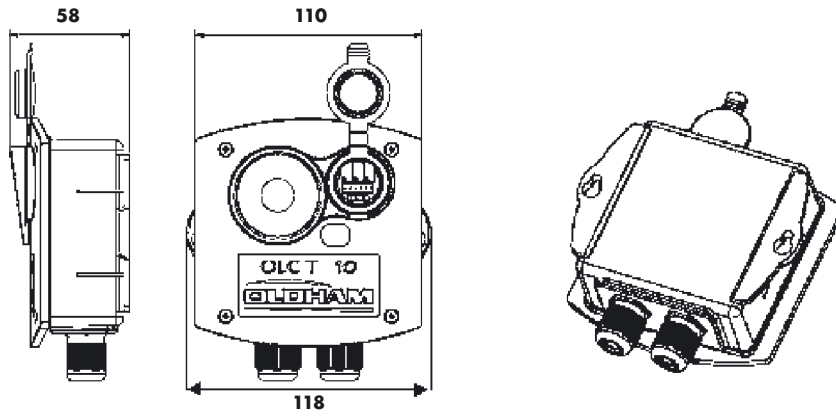

Wiring arrangement between OLCT 10 and MX 15 control unit

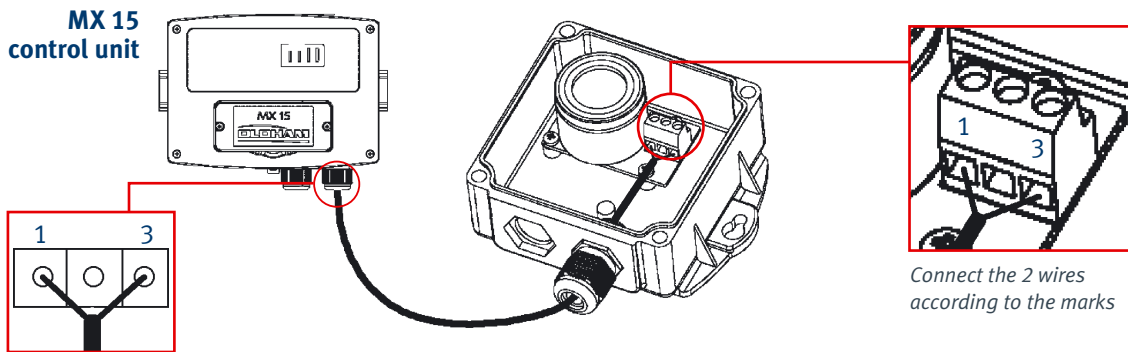

Wiring arrangement between 2 OLCT 10 (same detection for both) and MX 15

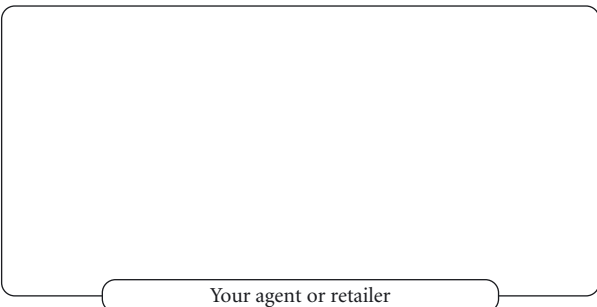
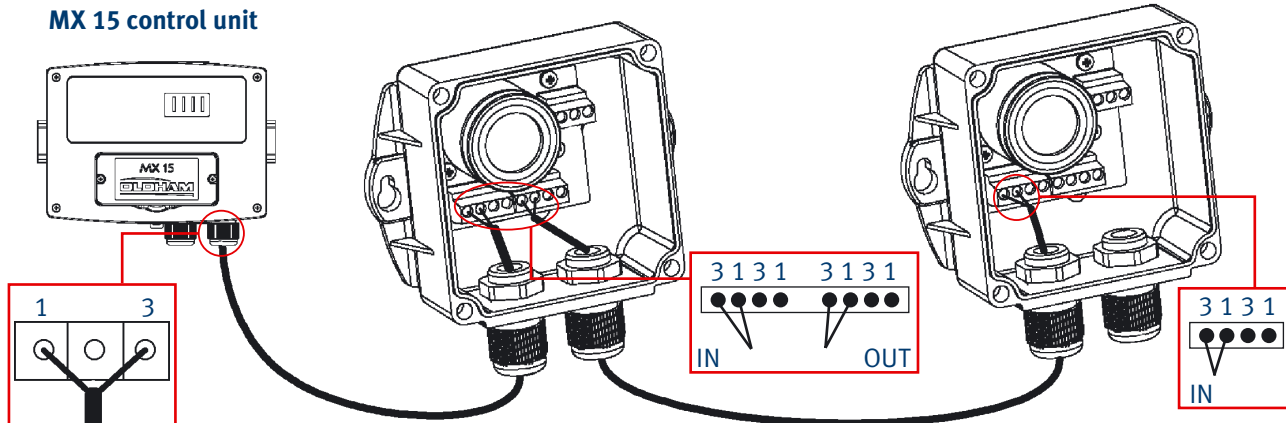

OLDHAM

Group

Plant and head office : Z.I. Est - rue Orfila
 B.P. 417 - 62 027 ARRAS Cedex FRANCE
 Tel. : 33 3 21 60 80 80 Fax : 33 3 21 60 80 00
 Web site : <http://www.oldhamgas.com>

EXPORT DEPARTMENT :
PHONE : 33 3 21 60 80 80
FAX : 33 3 21 60 80 05

Winter- Oldham group
 Germany

(49) 231 924 10
 (49) 231 924 125
info@winter-gmbh.com

OLDHAM
 Italia

(011)-3801371
 (011)-3806613
info@oldham.it

OLDHAM
 Česká Republica

(420) 234 622 222/3
 (420) 234 622 220
oldham@oldham.cz

OLDHAM
 Romania

(40) 21 312 37 56
oldham@fx.ro

OLDHAM
 Switzerland

(41) 26 652 51 18
 (41) 26 652 51 19
info@oldham.ch

OLDHAM
 United Kingdom

(44) 0 1782 562002
 (44) 0 1782 564414
sales@oldham.biz