



## FEATURES

- \* safety shut off valves for gas, air and oil
- \* EN161 approved; EC certificated
- \* robust construction to IP54
- \* electro-hydraulic slow opening operation
- \* closure in less than 1 second
- \* fitted with closed position switch (volt free)
- \* optional built in or remote manual reset switch
- \* optional open position switch (volt free)
- \* flanged and screwed body connections
- \* ultra high flow rate/connection size ratio
- \* removeable strainer for easy maintenance
- \* suitable for vertical or horizontal mounting
- \* plugged test points both sides of body
- \* remote emergency stop switches available
- \* remote thermal fuses available
- \* 20mm entry for cable or conduit entry
- \* open position indicator
- \* available in 110V and 230V 50Hz versions

### ADDITIONAL FEATURES OF 200MM AND 250MM POWERSEAT

- \* red l.e.d. Power on' indicator
- \* amber flashing l.e.d. valve opening' indicator
- \* green l.e.d. Valve open' indicator
- \* membrane type control panel on actuator
- \* integral manual reset switch as standard
- \* manual reset switch can be wired in or out
- \* open position switch (volt free) as standard

## DESCRIPTION

The **Powerseat** family is an electro-hydraulically operated range of gas safety shut-off valves with ultra high flow rates and a range of associated accessories. Their primary function is the on-off control of low pressure combustible gases, air and oil and may be used for both control and safety shut-off purposes. The valves are suitable for the three families of combustible gas as follows, 1st, town gas; 2nd, natural gas and 3rd, Liquefied Petroleum Gases. They are suitable for oil with a viscosity of up to 200 seconds Redwood.

The valves are normally closed, i.e. energise to open, and are operated from a.c. mains at 230 or 110 volts. Electro-hydraulic operation ensures a smooth, controlled opening at low speed whilst closure time is less than 1 sec.

**Powerseats** are available in connection sizes from 1½" (DN40) to 3" (DN80) screwed, and from DN65 (2½") to DN250 (10") Flanged, thereby covering an extremely wide range of commercial and industrial applications. Complementary high quality solenoid valves are available to cover smaller sizes, where the ultra high flow rate of the Powerseat is not so important

Valve construction consists of a die cast aluminium body, a removable stainless steel strainer and an actuator having the valve closure head as an integral part. The actuator may be removed from the body for servicing and access to the strainer without removal of the body from the line.

The actuator consists of a pump and motor, a relief valve, operating cylinder, piston and push rod, valve head and seals, hydraulic fluid and electrical switchgear. When the valve is energised the relief valve closes, the motor starts and the pump forces fluid into the cylinder driving the valve open. At this point the closed position switch contacts change state (this does not affect the operation of the valve as they would typically be connected to an external burner

sequence control). When the fully open position is reached a limit switch (adjustable) changes state, switches off the pump motor and illuminates an amber neon indicator on the case to show that the valve is fully open. Where a factory fitted optional open position switch is fitted this will also change state, again without affecting the valve operation as it will be connected to an external control system.

The relief valve remains closed and will do so until power is removed. Removal of power causes the relief valve to open and the safety shut off valve to close.

Manual reset switches, either integral or remote mounting, are available as accessories for on site fitting. When wired in, manual intervention is required to operate the valve after mains interruption, i.e. after a power cut or when the valve is first energised. To facilitate this, the 'reset button' is momentarily depressed latching the reset switch in the 'on' position allowing the valve to operate.

### Additional features of the 200 and 250mm Powerseat

These valves feature a membrane covered control panel on the actuator. Upon energising the valve a red LED illuminates on the control panel and remains illuminated whilst power is 'on' to the valve.

Whilst the pump is running an amber LED on the control panel flashes to indicate that the valve is opening. This goes out when the valve is fully open and is replaced with a green 'open' LED.

The valves feature an integral 'manual reset switch' as standard which can be wired out at any time. Operation of the switch is otherwise identical to the optional switches on the smaller valves.

# FLOW

## BC6683 to BC6687 MODELS

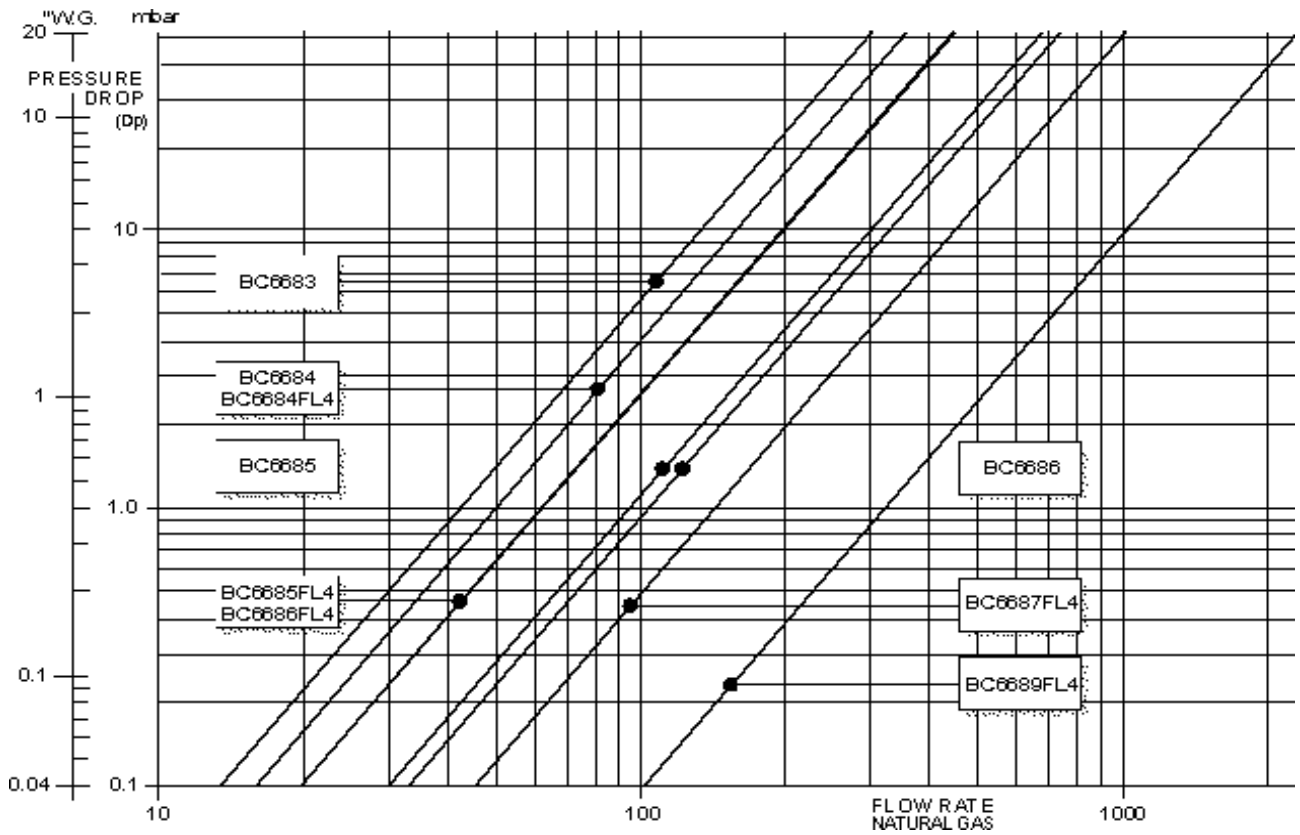

## BC6689 to BC66811 MODELS

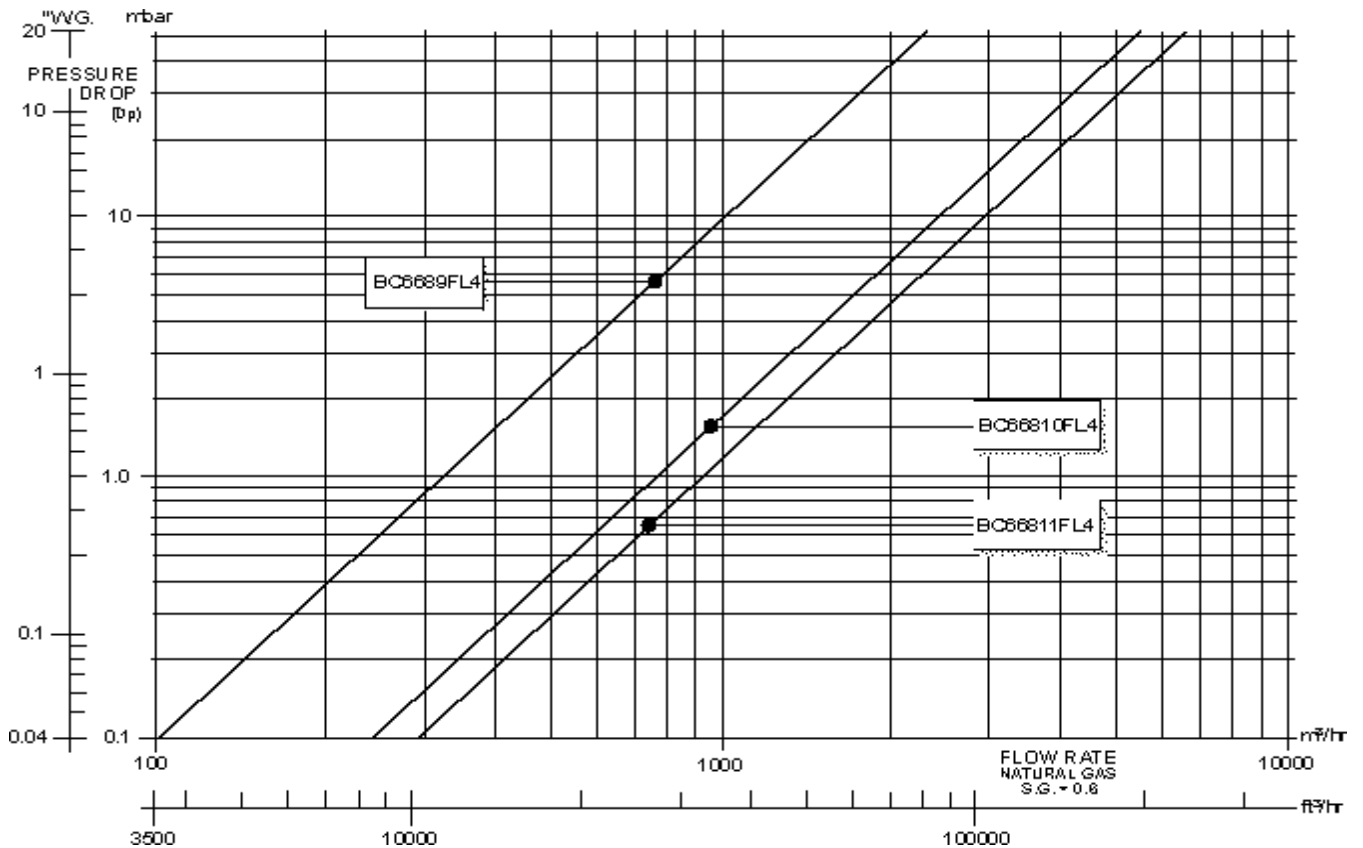

# DIMENSIONS

**BC6683  
BC6684**

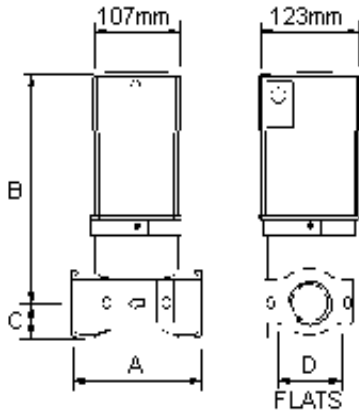

**BC6685  
BC6686**

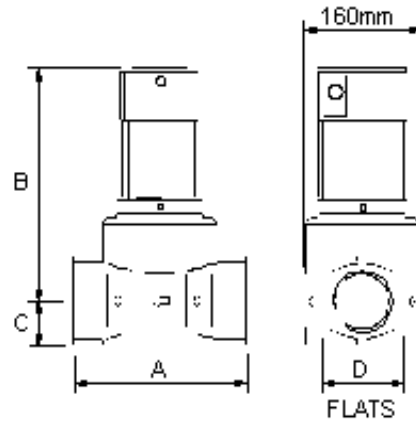

**BC6685FL4  
BC6686FL4  
BC6687FL4**

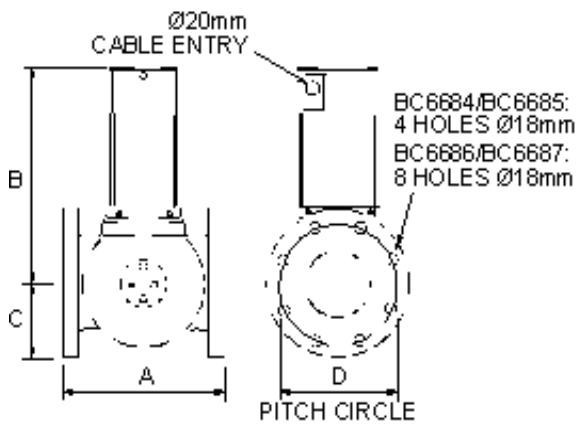

**BC6689FL4**

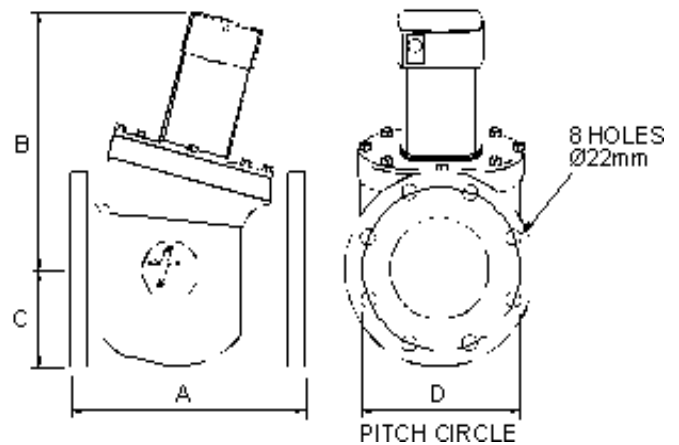

**BC66810FL4  
BC66811FL4**

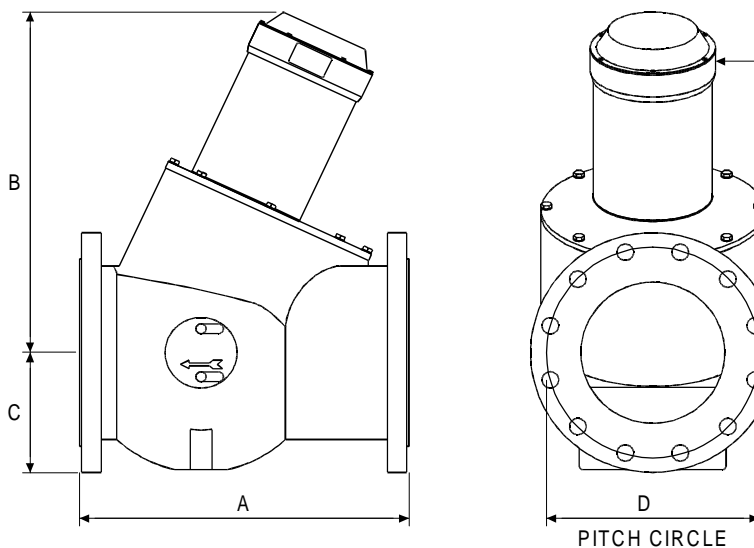

# SPECIFICATION

**Media:**

Non-corrosive gases, air, oil (up to 200 sec. Redwood No.1)  
 Combustible gases, families 1 (town gas), 2 (natural gas) and 3 (L.P.G.)

**Media Temperature Range:**

-15°C to +60°C

**Ambient Temperature Range:**

-15°C to +60°C

**Opening Speed:**

BC6683 - BC6687: 10 seconds max.  
 BC6689: 30 seconds max.  
 BC66810 & BC66811: 70 seconds max.

**Closing Speed:**

< 1 second

**Electrical:**

Versions available: 110V or 230V 50Hz  
 220V 60Hz

All models have screw terminals and provision for earthing

**Rating:**

BC6683 - BC6689  
 Opening - 110V version 160VA  
           220/230V version 200VA  
 Fully Open - all versions 18VA  
 BC66810 - BC66811  
 Opening - 220VA  
 Fully Open - 37VA  
 Closed and Open Position Switch Ratings:  
 Volt free contacts  
 250V a.c. or 30V d.c. 5A max. resistive  
                                   2A max. inductive

**Environmental:**

IP54

**Manual Reset Switch:**

BC66810 & BC66811 models only  
 Time to drop out after removal of power - typically 10ms

**Mounting:**

Vertical or Horizontal, actuator in upper hemisphere - see installation section.

**Connections:**

Flanged or screwed - see table below

Flanged connections to BS4504 Section 3.2 Table 11; PN16 flanges (ISO7005)

Screwed connections to BS21 Rp designated (ISO7-1) threads

**Pressure Test Points:**

Upstream and downstream of seat, both sides of body, plugged Rp ¼

**Strainer:**

All models: removable stainless steel mesh

**Approvals:**

All models approved to EN161, Class A Group 2 construction

EC certificated

**Maximum Operating Pressure:**

Maximum forward and reverse operating pressures - see table below

**Flow**

See table below and chart at page 3

**Dimensions and Weight**

See table below

Valve Type	Connection	Actuator	Orifice Dia. mm	Maximum Natural Gas S.G.0.6		Maximum Operating Pressure		Nett Weight kg	Dimensions (Refer to diagram)			
				p2.5mbar m3/hr	p 1"W.G. ft3/hr	Forward mbar	Reverse mbar		A	B	C	D
BC6683	1.5" Screwed	BC668S	50	67	2345	1000	150	5.0	160	280	40	79
BC6684	2" Screwed	BC668S	50	80	2800	1000	150	4.6	160	280	40	79
BC6685	2.5" Screwed	BC668LS	76	150	5250	350	150	7.4	235	308	58	110
BC6685FL4	65mm Flanged	BC668HS	76	100	3500	350	150	21.5	219	308	76	145
BC6686	3" Screwed	BC668LS	76	165	5775	350	150	7.0	235	308	58	110
BC6686FL4	80mm Flanged	BC668HS	76	100	3500	350	150	23.0	219	334	92	160
BC6687FL4	100mm Flanged	BC6687S	96	220	7700	250	150	29.5	248	347	101	180
BC6689FL4	150mm Flanged	BC6689S	150	510	17850	250	150	60.0	356	410	145	240
BC66810FL4	200mm Flanged	BC66810S	200	1200	42000	250	150	102.0	458	485	170	295
BC66811FL4	250mm Flanged	BC66811S	250	1430	50050	250	150	160.0	540	530	203	355

# INSTALLATION

## CONNECTIONS

Observe local codes of practice, i.e. use of registered installers etc.

Ensure gas supply is switched off and connecting pipework is clean before installation. Use thread sealant or flange gasket as appropriate. Ensure that one of the three arrows on the actuator is pointing upwards with pipework vertical or horizontal. On screwed connection valves actuator can be rotated through 90° in the valve body to accomplish this. Ensure electrical supply is protected by mcb or a slow blow T1A fuse. Remove actuator cover and fit cable gland or suitable adaptor into housing.

Refer to diagrams below and make electrical connections as applicable

## CLOSED POSITION SWITCH

Change-over switch generally used in normally closed contact position for burner controls, i.e. closed when valve is closed. May also be wired normally open for other purposes. Contacts are volt free

## OPEN POSITION SWITCH

**Models BC6683 - BC6689.** Optional factory fitted SW' switch has 'normally open' contacts which close when the valve is fully open.

**Models BC66810 and BC66811.** Standard factory fitted change-over switch. Connecting 'common' and 'normally closed', contacts are closed when valve is closed. Connecting 'common' and 'normally open', contacts are closed when valve is fully open. Contacts are volt free.

*Note. Closed and Open Position Switches are factory set and require no adjustment.*

## MANUAL RESET SWITCH

**Models BC6683 to BC6689.** Optional switches parts no's BC66RS (integral) or BC66RSR (remote) are available each supplied with its own installation instructions

**Models BC66810 and BC66811.** Factory fitted as standard, if reset facility is not required link terminals 1 and 2 as shown.

## COMMISSIONING

Refit actuator cover. Leak test gas connections. Energise valve.

### BC6683 to BC6689 Models.

Amber neon on switch housing will illuminate when valve fully open

### BC66810 and BC66811 Models.

Red 'power on' LED will glow. Depress reset button if manual reset switch wired in. Amber 'opening' LED will flash until valve fully open when green 'open' LED will illuminate.

## ELECTRICAL CONNECTIONS BC6683 - BC6689

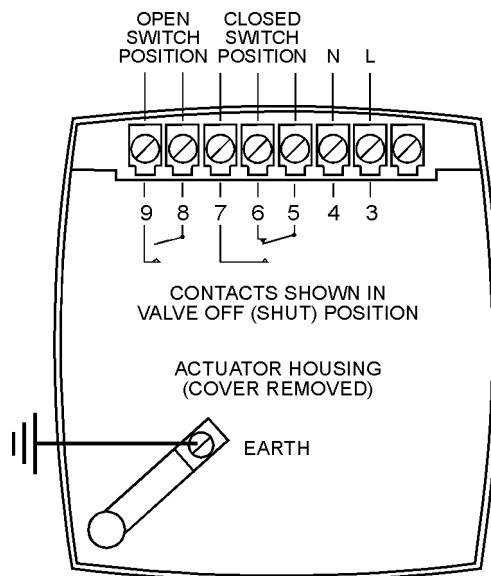

**Note.** Not all terminals are fitted to every valve

## ELECTRICAL CONNECTIONS BC66910 & BC66811

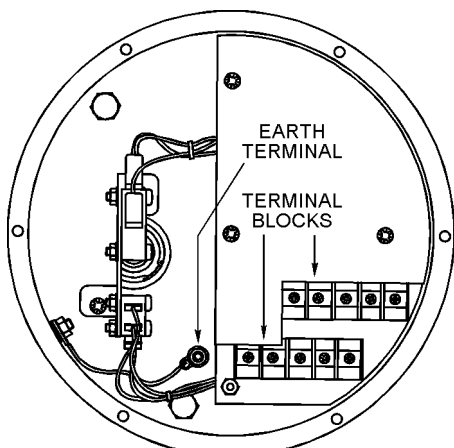

CABLE ENTRY

VIEW ON INSIDE OF SWITCH HOUSING

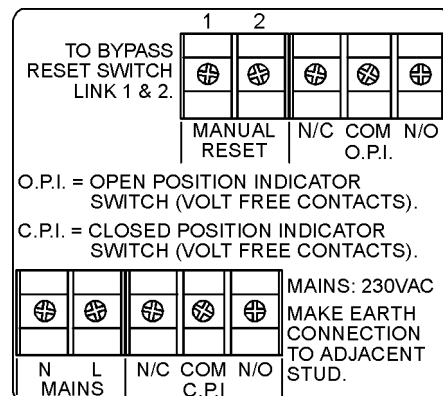

TERMINAL BLOCK WIRING

# MAINTENANCE

There are no user serviceable parts in the actuator except for the valve rubber, which may be cleaned with turpentine substitute. The strainer may also be removed from the valve body for cleaning. To remove the actuator to perform these tasks, isolate the gas supply and proceed as follows.

## MODELS BC6683 TO BC6687

Energise to open valve, unscrew the four socket screws around the body neck and withdraw actuator. **On no account must the socket screws in the actuator base plate be touched.** De-energise and carry out cleaning. If fitting a new actuator isolate the electrical supply and

**Note.** For guidance only. Full instructions appear in literature supplied with valve

reconnect to new actuator. Energise, refit actuator to body and tighten the four screws around body neck to retain. De-energise and leak test.

## MODELS BC6689 TO BC66811

Energise to open valve, unscrew the 8 hexagon bolts around actuator flange and withdraw actuator.

De-energise and carry out cleaning. If fitting a new actuator isolate the electrical supply and re-connect to new actuator. Energise, refit actuator to body and tighten the eight bolts around actuator flange to a torque of **20Nm (14.75 lb ft)** to retain. De-energise and leak test.

# ACCESSORIES

## POWERLINK



**BC66MRF**

*Manually Resettable Electro-Thermal Fuse*

## THERMAL FUSES

### MANUALLY RESETTABLE VERSION FEATURES

A remote mounted thermally operated manually resettable fuse in a vented metal housing. Mounting orientation universal. Wired in series with the Safety Shut Off Valve, the fuse will open a circuit at a predetermined temperature, interrupting the supply to the valve, which will then close. A knob on the front of the unit is rotated through a quarter turn to reset.

### INSTALLATION

The fuse is provided with a backplate for fixing and can be mounted on to a standard circular conduit box. It is recommended that the housing is mounted between 0.3 and 1 metre above an area where fire may occur. The thermal fuse is single pole; electrical connections are *via* a screw terminal block on the fixing plate. There is provision for earthing *via* a stud adjacent to the terminal block.

### SPECIFICATION

Product Code:	BC66MRF
Electrical rating:	single pole changeover 5A max. 230V a.c. (resistive and inductive)
Fusing temperature:	from 70°C; 10°C reset differential

### NON RESETTABLE VERSION FEATURES

A remote mounted thermally operated non resetting fuse in a vented metal housing suitable for wall or conduit mounting. Wired in series with the Safety Shut Off Valve, the fuse will open a circuit at a predetermined temperature, interrupting the supply to the valve, which will then close.

### INSTALLATION

The fuse is suitable for screw fixing on to a flat surface or may be supported on the end of a rigid conduit pipe. It is recommended that the housing is mounted between 0.3 and 1 metre above an area where fire may occur. The thermal fuse is single pole; electrical connections are *via* a screw terminal block inside the housing.

### SPECIFICATION

Product code:	BC66ETF
Electrical rating:	15A max. 230V a.c.
Fusing temperature:	72°C standard others available



**BC66ETF**

*Electro-Thermal Fuse*

# ACCESSORIES

## POWERSET



**BC66RS**  
Integral  
Model



**BC66RSR - Remote Model**

## MANUAL RESET SWITCHES

### FEATURES

A push button operated switch which isolates the electrical supply to the valve in the event of power failure. When power is subsequently restored to the valve, the push button must be depressed before the valve will open, after which operation is normal.

*Integral and remote versions are available*

### INSTALLATION

*Integral Version:* available only as an accessory, and cannot be fitted into actuators with 'SW' open position switch. Install into unused cable entry hole in either side of actuator housing. Electrical connections made to existing screw terminals on actuator.

*Remote Version:* suitable for screw fixing to a flat surface. Route electrical supply to valve through unit; electrical connection *via* screw terminals, cable entry 20mm diameter.

### SPECIFICATION

Product code:

Integral Model - BC66RS (add voltage as suffix)  
Remote model - BC66RSR (add voltage as suffix)

Consumption: 1VA max.

Drop out time: typically 10ms

Protection: integral - IP40; remote - IP65

## POWERSEV



**Powersev Switches**

### DIMENSIONS, mm

MODEL	Height	Width	Depth	Mount
BC66ESB	80	80	82	50x65
BC66ESB/P	85	71	94	49x54
BC66ESB/K	82	71	94*	54x67

\* Plus key

## EMERGENCY CUTOUT SWITCHES

### FEATURES

A remote mounted push-to-break contact/twist-to-reset switch for emergency use. Available in metal or plastic wall mounting box, with or without key switch operation.

### INSTALLATION

Screw fix to flat surface. Connect electrical supply through single pole switch block *via* screw terminals. Other contact blocks for 3 phase, double pole or normally open contacts available for retro-fitting.

### SPECIFICATION

Product Codes: Metal box - BC66ESB  
Plastic box - BC66ESB/P  
Key switch op. - BC66ESB/K

Contacts: 10A 500V max. single pole

Temperature range: -25° C to + 70° C

Protection: BC66ESB - IP65, others IP40

## PROVENGAS



**Provengas**

## AUTOMATIC GAS PROVING SYSTEM

### FEATURES

An automatic proving system for gas installations comprising a control panel and an isolating unit. Connects into gas supply to safety shut off valve and proving cycle is manually initiated from control panel. Has integral time switch for timed shut down and features key switch and emergency cut out switch for safety and security. Easy installation and commissioning, for use with any solenoid or electro-hydraulic gas safety shut off valves

### INSTALLATION

The isolating unit may be either wall mounted or fixed directly to the gas valve. The control panel may be mounted in any convenient location in the same building as the isolating unit

### SPECIFICATION

Product Code: PG001  
Compatibility: 1st, 2nd & 3rd Family Gases  
Electrical Supply: 230V 50Hz, 2A fused  
Gas Supply: 20mbar to 60mbar  
Ambient and Media Temp.: 0° C to 55° C  
See separate Literature ref CAT055/A or contact Black Teknigas

**BLACK TEKNIGAS LTD.** Unit 3, Bydand Lane, Little Paxton, Huntingdon Cambridgeshire, PE19 6EG, England  
Tel (+44) 01480 407074; Fax (+44) 01480 407076; www.blackteknigas.com; e mail: sales@blackteknigas.com

We invest heavily and continuously in product development, accordingly we reserve the right to alter both the product range and product specifications without prior notice.